

# User & Installation Manual

## LT-1000 NRU

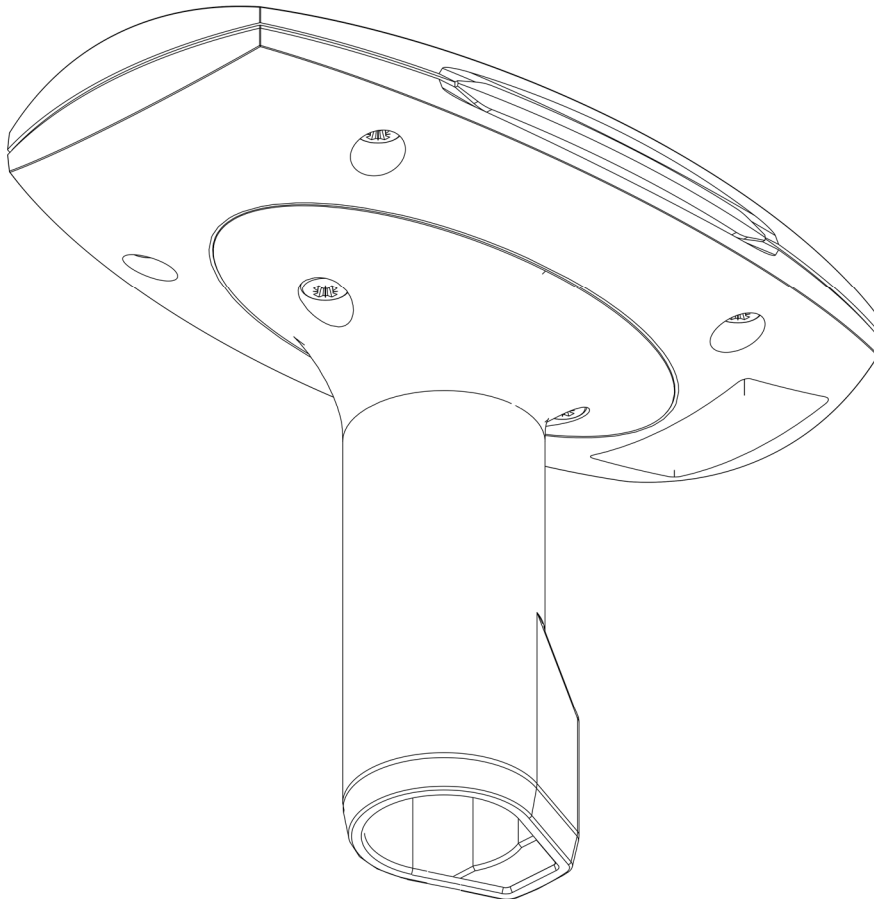

**Document Number:** 95-100178 REV. 1.00

**Release date:** January 19, 2016

Copyright © Lars Thrane A/S

Denmark

ALL RIGHTS RESERVED



**This Document is of © copyright to Lars Thrane A/S. It contains proprietary information, which is disclosed for information purposes only. The contents of this document shall not in whole or in part be used for any other purpose without prior permission from Lars Thrane A/S.**

## Disclaimer

Any responsibility or liability for loss or damage in connection with the use of this product and the accompanying documentation is disclaimed by Lars Thrane A/S. The information in this manual is provided for information purposes only, is subject to change without notice, and may contain errors or inaccuracies. Manuals issued by Lars Thrane A/S are periodically revised and updated. Anyone relying on this information should acquire the most current version e.g. from Lars Thrane A/S. Lars Thrane A/S is not responsible for the content or accuracy of any translations or reproductions, in whole or in part, of this manual from any other source.

## Copyright

© 2016 Lars Thrane A/S. All rights reserved.

## Disposal

Old electrical and electronic equipment marked with this symbol can contain substances hazardous to human beings and the environment. Never dispose these items together with unsorted municipal waste (household waste). In order to protect the environment and ensure the correct recycling of old equipment as well as the re-utilization of individual components, use either public collection or private collection by the local distributor of old electrical and electronic equipment marked with this symbol. Contact the local distributor or dealer for information about what type of return system to use.



## IMO and SOLAS

The equipment described in this manual is intended for use on leisure and commercial marine boats not covered by the International Maritime Organization (IMO) and Safety of Life at Sea (SOLAS) regulations.

## Safety Instructions for Installer & Operator

The following safety instructions must be observed during all phases of operation, installation, service and repair of this equipment. Failure to comply with these precautions or with specific warnings elsewhere in this manual violates safety standards of design, manufacture and intended use of the equipment.

Lars Thrane A/S assumes no liability for the customer's failure to comply with these requirements.

### Instructions for the Installer

#### **WARNING - Product installation**

To ensure correct performance of this equipment, it is strongly recommended that professionals, with expertise, properly trained, and likewise authorized within the industry is completing the installation.

#### **WARNING – Turn off power switch**

Turn off the main power switch before installing the equipment described in this manual. Do not connect or disconnect equipment when the main power switch is on.

#### **WARNING – Use supplied cable**

Use the supplied power and communication cable for connecting the equipment.

#### **WARNING – Input Power**

The input voltage range is: 9-40 VDC.

#### **WARNING – Power supply protection**

Make sure that the power supply is adequately protected by a fuse or an automatic circuit breaker when installing the equipment.

#### **WARNING - Explosive atmosphere**

Do not operate the equipment in the presence of flammable gases or fumes. Operation of any electrical equipment in such an environment constitutes a definite hazard.

#### **WARNING - Compass safe distance**

The minimum compass safe distance is 0.3 m. (1').

### Instructions for the Operator

#### **WARNING – Do not disassemble**

Do not disassemble or modify this equipment. Fire, electrical shock, or serious injury can result.

#### **WARNING – Keep away from live circuits**

Operational personnel must not remove product enclosure. Do not service the equipment, with the communication cable connected. Always disconnect and discharge unit, cable and circuits before touching them.

#### **WARNING - Permanent watch**

In case of smoke or water leaks into the equipment, immediately turn off the power. Continued use of the equipment can cause fire or electrical shock. Keep access and permanent watch of the equipment in order to prevent any unwanted escalation.

#### **WARNING - Safe navigation**

This product is intended only as an aid to navigation and must never be used in presence to sound navigation judgement.

#### **WARNING - Turn off the autopilot**

During deviation calibration and offset adjustment of the product, it is strongly recommended to turn off the autopilot in order to avoid rapid changes in the heading of the boat.

**If the safety precautions and warnings above are not followed, then the product warranty is void.**

## Required information for the reader

Throughout this document, essential information will be presented to the reader. The following text (emphasized) has the following meaning and/or implication:

**WARNING:** A 'Warning' is an Operation or Service procedure that, if not avoided, may cause a hazard situation, which could result in personnel death or serious injury.

**NOTE:** A 'Note' provides essential information to the reader.

**IMPORTANT:** Text marked 'Important' provides essential information to the reader, and is key information to the user in order for the equipment to work properly. Personnel injury or damage to the equipment can occur if instructions are not followed.

## About this manual

### Intended readers

This is a User & Installation Manual for LT-1000 Navigation Reference Unit, LT-1000 NRU. The manual is primarily intended for installers and service personnel.

Personnel installing or servicing the system should be professionals, with technical expertise, properly trained, and likewise authorized.

All safety instructions and guidelines in this manual must be observed. The safety instructions are listed in the beginning of the manual. The guidelines are to be found in the separate chapters, where it is needed.

### Manual overview

This manual has the following chapters:

- **Introduction** – provides a high-level description of the product, technology, performance, installation options, and installation steps to be completed.
- **Quick installation guide** – a short guide providing a minimum of information to complete an installation.
- **Installation** – a complete description of mounting and installation details, with a step-by-step instruction for both pole and roof mount installations.
- **Connecting** – a description of the unit connector, 8-pin multi cable, connecting to NMEA 0183, connecting to NMEA 2000, and connecting the LT-Service Tool.
- **Deviation calibration** – a description of the deviation calibration pattern to be performed after an installation (mounting and connecting) and the step-by-step calibration procedure.
- **Configuration using LT-Service Tool** – a short description of the LT-Service Tool. A PC-program, communicating over NMEA 0183, which is supporting configuration and maintenance functions.
- **Service and repair** – a short description of what to do in case of a defective unit.
- **Troubleshooting** – if the unit is not working as expected, please check this guide to help resolve the problem

This manual has the following appendixes:

- Outline Drawings
- Performance
- Specifications
- NMEA 0183 Sentences
- NMEA 2000 PGNs
- LT-Service Tool (commands)
- Declaration of Conformity

### Software versions

This manual corresponds to the following software:

Software Versions	
Description	Version
LT-1000 NRU	1.01
LT-Service Tool	1.01

TABLE 1: SOFTWARE VERSIONS

## Record of Revisions

<b>Rev.</b>	<b>Description</b>	<b>Release Date</b>	<b>Initials</b>
1.00	Original document	January 19, 2016	PT

## Table of Contents

<b>INTRODUCTION.....</b>	<b>1</b>
<b>QUICK INSTALLATION GUIDE.....</b>	<b>3</b>
<b>INSTALLATION .....</b>	<b>5</b>
<b>CONNECTING.....</b>	<b>20</b>
<b>DEVIATION CALIBRATION .....</b>	<b>27</b>
<b>CONFIGURATION USING LT-SERVICE TOOL .....</b>	<b>29</b>
<b>SERVICE AND REPAIR.....</b>	<b>32</b>
<b>TROUBLESHOOTING.....</b>	<b>33</b>
<b>APP. A - OUTLINE DRAWINGS .....</b>	<b>34</b>
<b>APP. B - PERFORMANCE.....</b>	<b>36</b>
<b>APP. C - SPECIFICATIONS.....</b>	<b>37</b>
<b>APP. D - NMEA 0183 SENTENCES .....</b>	<b>38</b>
<b>APP. E - NMEA 2000 PGNS.....</b>	<b>40</b>
<b>APP. F - LT-SERVICE TOOL (COMMANDS).....</b>	<b>41</b>
<b>APP. G - DECLARATION OF CONFORMITY .....</b>	<b>42</b>



## Introduction

Congratulations on your purchase of the LT-1000 Navigational Reference Unit (NRU)!

The LT-1000 Navigation Reference Unit (NRU) is a maritime navigation product from Lars Thrane A/S. The LT-1000 NRU is designed for the leisure as well as the professional maritime markets. The LT-1000 unit meets all standards and certification requirements needed for worldwide maritime navigation equipment.

### Performance

The LT-1000 NRU is a small, compact, and very advanced unit with 12 precision sensors (magnetometers, gyros, accelerometers, barometer, thermometer, and GNSS). With the use of sensor-fusion and Kalman filtering, the LT-1000 NRU outputs: true heading, magnetic heading, roll, pitch, position, satellite information, ground speed, course over ground, air pressure, and temperature in real-time, with high precision and resolution. The LT-1000 NRU includes advanced technologies such as:

- Kalman filtering
- Calculation of magnetic variation based on the World Magnetic Model (WMM)
- Compensation of soft and hard iron (deviation)
- Built-in magnetometer calibration algorithm
- Receive and track multiple satellite systems (GPS, GPS & GLONASS, or GPS & BeiDou)
- Support for Satellite-Based Augmentation System (SBAS): EGNOS, WAAS and MSAS

The LT-1000 NRU makes use of the latest technology within GNSS receivers, with market leading acquisition and tracking performance.

The LT-1000 NRU is designed and built for the demanding and rough environment at sea and with an operational ambient temperature range from -40°C to +55°C (-40°F to +131°F).

### Installation & Navigation

The LT-1000 Navigation Reference Unit is easy to mount on a 1" pole (optional installation: roof mount) with a single cable supporting NMEA 0183, NMEA 2000, and power. The built-in magnetometer calibration algorithm will quickly compensate for heading deviation, and the LT-1000 NRU will output reliable navigation data. An external LT-Service Tool is available for optional configuration and maintenance of the LT-1000 NRU.

More than 40 years of experience have been put into the design and construction of the advanced LT-1000 NRU, with an exceptional performance and specification level.

## Installation Guide

The following steps, with reference to relevant chapters, will provide you with information, considerations, and guidance on how to complete a successful installation:

- |         |                      |  |
|---------|----------------------|--|
| Step 1: | Mounting the Unit    | see <i>Installation</i> on page 5.   |
| Step 2: | Connecting the Unit  | see <i>Connecting</i> on page 20.  |
| Step 3: | Calibrating the Unit | see <i>Deviation calibration</i> on page 27.   |
| Step 4: | Configuring the Unit | see <i>Configuration using LT-Service Tool</i> on page 29 and <i>Mounting offset adjustment</i> on page 31 (optional). |

**NOTE:** A quick installation overview is presented in the *Quick Installation Guide* on page 3. Here most of the necessary information is provided to perform a fast installation and take the product in use. It is recommended to use the entire LT-1000 User & Installation Manual as guidance for the best possible and complete installation.

# Quick Installation Guide

## LT-1000 Navigation Reference Unit

Congratulations on your purchase of the LT-1000 Navigational Reference Unit (NRU)!

The LT-1000 NRU is a small, compact and very advanced unit with 12 precision sensors: Magnetometers, Gyros, Accelerometers, Barometer, Thermometer, and GNSS receiver.

**NOTE:** Refer to the 95-100178 LT-1000 User & Installation Manual for detailed information on installation requirements and guidance.

### Unpacking

Unpack the LT-1000 NRU and check that the following items are present:

- LT-1000 NRU (incl. pole mount and cable plug)
- LT-1000 NRU Roof Mount (incl. screws for installation)
- 10m Cable Multi 8-pin Simple-Cut (M)
- Screw-in Conn. NMEA 2000 Micro-C (M)
- Quick Installation Guide
- Unit Test Sheet

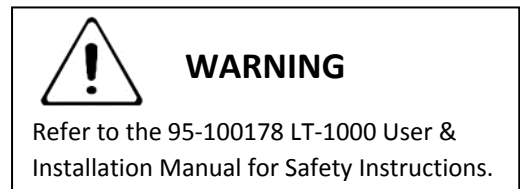

### Installation

The LT-1000 NRU DIP-switch is configured to 4.800 baud (NMEA 0183) and 'Open' (NMEA 2000) from the factory. Alternative DIP-switch settings are 38.400 baud (NMEA 0183) and 'Terminated' (NMEA 2000).

Mounting considerations:

- Mount the unit on a rigid structure with a minimum of exposure to vibration and shock
- Mount the unit in an area with an ambient temperature between -40°C and +55°C (-40°F to +131°F)
- Mount the unit far away from possible magnetic interference and power cables
- Mount the unit so that direct spray from seawater is avoided
- Mount the unit so that ventilation through the pole mount is possible

**IMPORTANT:** The pinol screw used for fastening the pole mount shall not exceed 0.8 NM (0.6 lbs/ft).

Connecting cables:

The LT-1000 NRU 8-pin female connector and the multi cable (simple-cut) interconnect details are listed in Table 2 and Figure 1.

LT-1000 NRU Cable and Connector		
Pin No.	Cable Color	Connector Pin Assignment
1	Brown	TxD+
2	Yellow	TxD-
3	Black	GND
4	White	CAN_H
5	Blue	CAN_L
6	Orange	RxD-
7	Green	RxD+
8	Red	Vsupply

TABLE 2: MULTI CABLE COLOR AND LT-1000 NRU 8-PIN CONNECTOR PIN ASSIGNMENT.

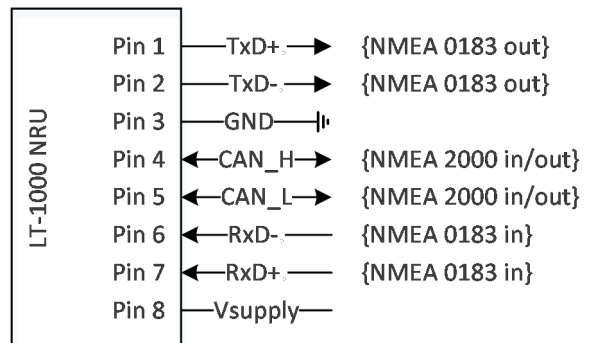

FIGURE 1: TRANSMIT AND RECEIVE DIRECTIONS FOR THE LT-1000 NRU.

**Deviation calibration**

After completed installation, and before configuring the LT-1000 NRU heading offset, it is required to perform a deviation calibration. The calibration must be performed in open and calm waters, and will determine the ship’s influence on the magnetic sensors.

The LT-1000 NRU will indicate absence of a valid calibration by outputting heading (true and magnetic) with a 5 degrees resolution. When a calibration has been successful, the heading will be output with full resolution.

The LT-1000 NRU will automatically perform a calibration when it detects the vessel is sailing a specific pattern. To trigger a calibration, guide the vessel through the following pattern. The best result is achieved at low speed (SOG), low rate of turn (ROT) and in calm waters.

**Step 1**

Keep a steady course ( $\pm 5^\circ$ ) for min. 10 s.  
SOG: 2–12 knots

**Step 2**

Make a full circle (360-450°) clockwise or counterclockwise  
ROT: 2-6°/s (1 -3 min.)  
SOG: 2-12 knots

**Step 3**

Make a full circle (360-450°) in opposite direction  
ROT: 2-6°/s (1 -3 min.)  
SOG: 2-12 knots

**Step 4**

Keep a steady course ( $\pm 5^\circ$ ) for min. 10 s.  
SOG: 2–12 knots

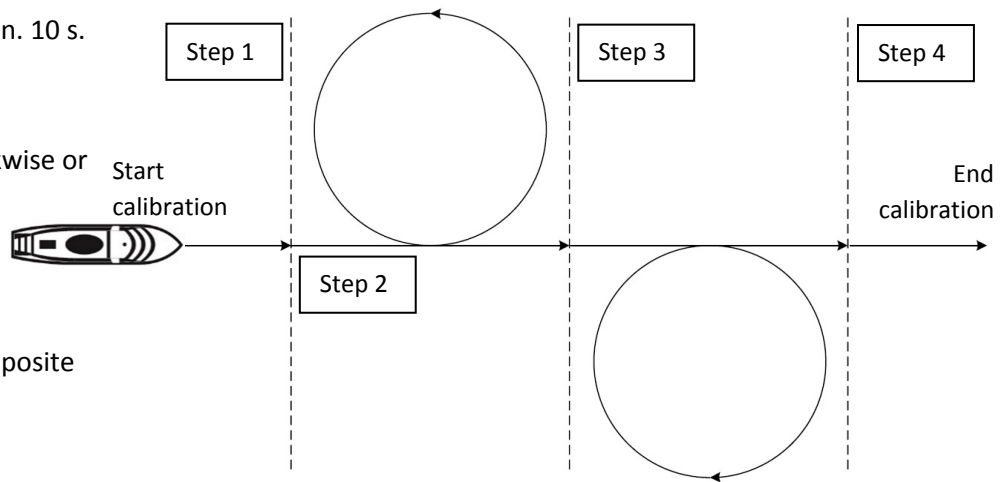

FIGURE 2: DEVIATION CALIBRATION PATTERN FOR THE LT-1000 NRU.

**IMPORTANT:** If the LT-1000 NRU is physically moved or rotated, it is required to perform a new calibration. Refer to the LT-1000 User & Installation Manual on how to use the LT-Service Tool to verify a subsequent calibration.

**Configuration (optional)**

Use the LT-Service Tool for optional configuration and offset adjustment of the LT-1000 NRU. The LT-Service Tool is a PC program (LT-Service\_vX.XX.exe) which may run on any Windows PC. The LT-Service Tool is connected to the LT-1000 NRU via the NMEA 0183 interface, see Figure 3.

LT-Service Tool functionality:

- Configuration of Heading offset
- Configuration of Pitch and Roll offset
- Configuration of Height Above Sea
- Configuration of GNSS receiver (GPS, SBAS, QZSS, GLONASS and BeiDou)
- Status of unit (POST, CM, general status)
- Monitoring of NMEA 0183 sentences
- Live Navigation data
- Generation of a Diagnostic Report

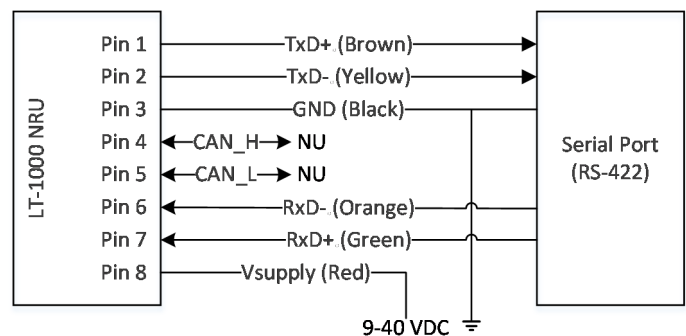

FIGURE 3: WIRING OF THE LT-1000 NRU TO A SERIAL PORT (RS-422).

# Installation

## Unpacking (in-the-box)

Unpack your LT-1000 NRU and check that the following items are present:

- LT-1000 NRU (incl. pole mount and cable plug)
- LT-1000 NRU Roof Mount (incl. screws for installation)
- 10m Cable Multi 8-pin Simple-Cut (M)
- Screw-in Conn. NMEA 2000 Micro-C (M)
- Quick Installation Guide
- Safety Instructions Sheet
- Unit Test Sheet

## Inspection

Inspect the shipping cartons and/or wooden box immediately upon receipt for evidence of damage during transport. If the shipping material is severely damaged or water stained, request that the carrier's agent be present when opening the cartons and/or wooden box. Save all box packing material for future use.

After unpacking the system and opening the cartons, inspect it thoroughly for hidden damage and loose components or fittings. If the contents are incomplete, if there is mechanical damage or defect, or if the system does not work properly, notify your dealer.

**WARNING:** To avoid electric shock, do not apply power to the LT-1000 NRU if there is any sign of shipping damage to any part of the unit or the outer cover. Read the Safety Instructions at the front of this manual before installing or operating the unit.

## Mounting and installation considerations

For optimum system performance, some guidelines on where to install or mount the LT-1000 NRU must be followed. It is recommended to mount the unit in a location, with as much free line of sight as possible, while making sure that the support structure fulfills the requirements for pole or roof mount installation:

- Mount the unit horizontally
- Mount the unit with free line of sight to GNSS satellites. If the Roof Mount is used for below deck installation, make sure that the unit is capable of receiving signals from the GNSS satellites
- Mount the unit on a rigid structure with a minimum of exposure to vibration and shock
- Mount the unit so that direct spray from seawater is avoided
- Mount the unit so that ventilation through the pole mount is possible
- Mount the unit in an area with an ambient temperature between -40°C and +55°C (-40°F to +131°F)
- Mount the unit away from possible magnetic disturbances (e.g. loudspeakers) and power cables
- Mount the unit at least 1 m. (3 ft.) away from radio transmitting antennas (VHF, UHF, MF-HF, Inmarsat, Iridium, Transmitting VSAT, etc.)
- Mount the unit at least 50 cm. (20") away from the following: Engines, generators, steel fuel and water tanks, bilge pump, anchor, anchor chain, and iron mast support
- Mount the unit with a minimum angle of 20 degrees towards a radar antenna (above or below).
- Mount the unit as close as possible to the ship's center of gravity and center line

**IMPORTANT:** The pinol screw used for fastening the pole mount shall not exceed 0.8 NM (0.6 lbf-ft).

### Condensation and water intrusion

If possible, install the LT-1000 NRU such that direct spray of seawater is avoided.

In some weather conditions there may occur condensation inside the LT-1000 NRU. The bottom part of the LT-1000 NRU is designed to lead water away from inside of the device.

Make sure not to cover the ventilation holes around the connector at the bottom side of the LT-1000 NRU. These holes are used for ventilation of the construction and for the pressure sensor. Also, make sure that there is free space around the communication cable through the pole mount.

It is recommended not to use pneumatic tools for cleaning the LT-1000 NRU, especially at a short distance, and directly at the split between the top and bottom part of the enclosure.

### Pole or Roof Mount installation

It is possible to use either a pole or roof mount, when installing the LT-1000 NRU, see Figure 4 (roof mount) and Figure 5 (pole mount).

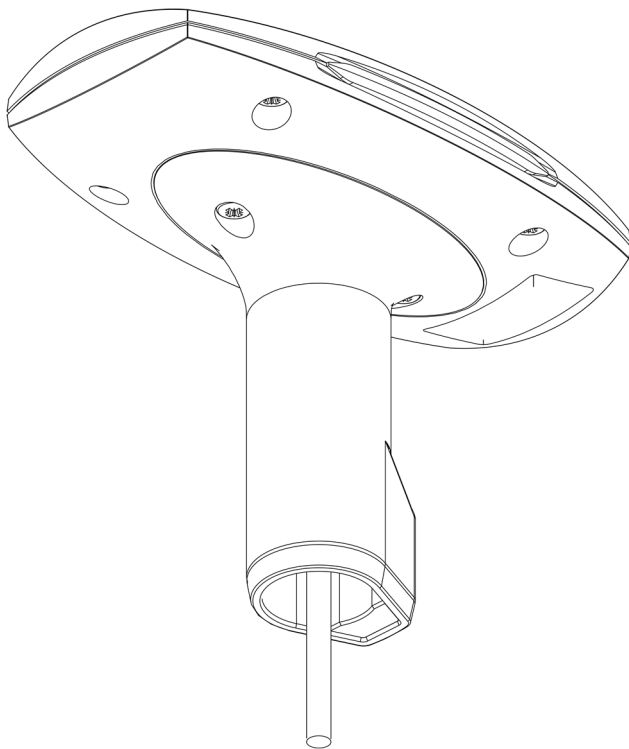

FIGURE 5: LT-1000 NRU WITH POLE MOUNT.

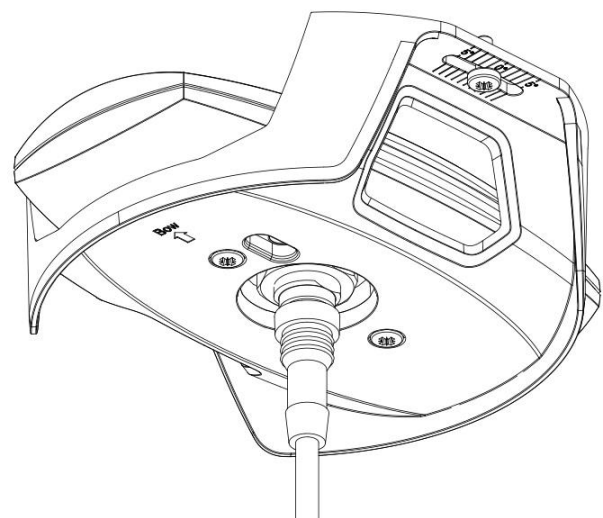

FIGURE 4: LT-1000 NRU WITH ROOF MOUNT.

The following two sub-chapters will in details, step-by-step, describe how to complete an installation with either a pole or roof mount

- Pole mount installation, see *Pole Mount installation* on page 7
- Roof mount installation, see *Roof mount installation* on page 15

**NOTE:** The LT-1000 NRU is delivered with both a Pole Mount and a Roof Mount. For further details on what is in-the-box, see *Unpacking* on page 5.

### Pole Mount installation

**Step 1:** Unpack the LT-1000 NRU and make a record of the unit serial number for support or warranty issues that could occur in the future.

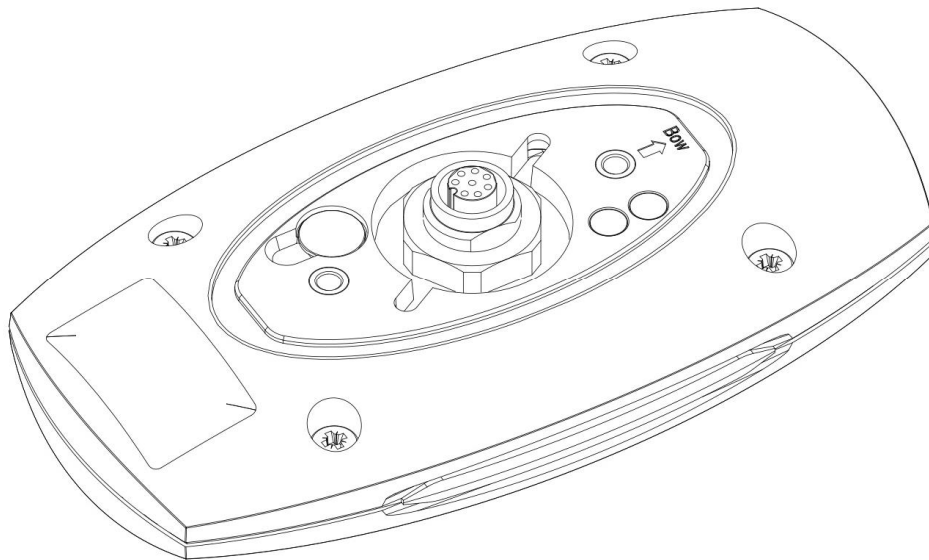

FIGURE 6: POLE MOUNT INSTALLATION STEP 1 (BOTTOM SIDE OF LT-1000 NRU)

**Step 2:** Remove cap for DIP-switch settings. Remember to re-insert the cap after configuration of the DIP-switch.

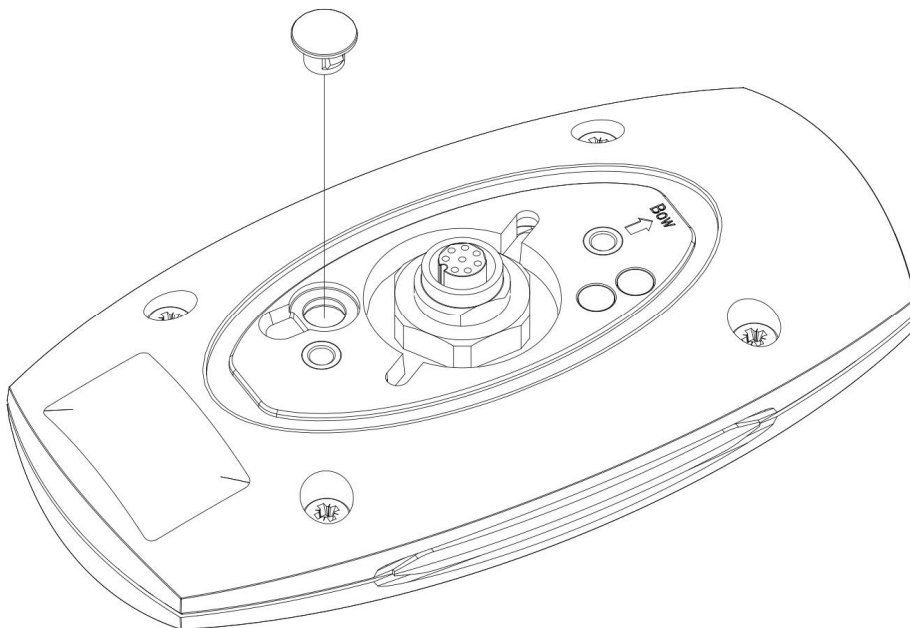
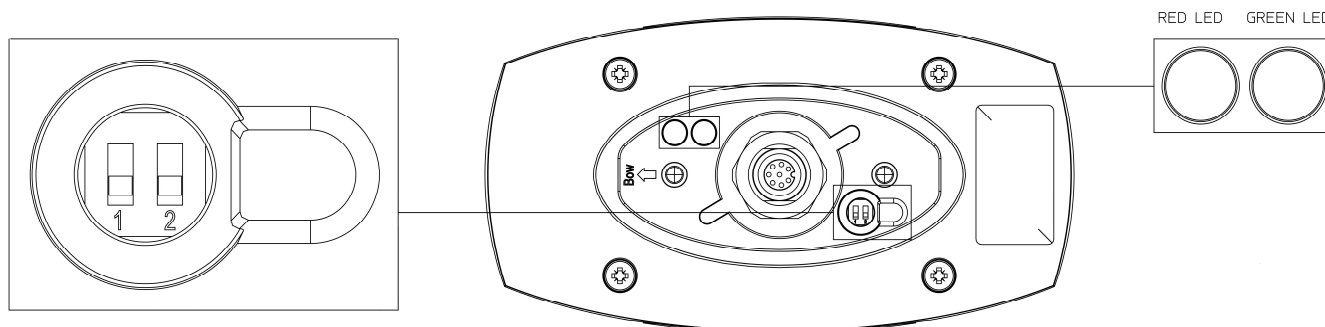

FIGURE 7: POLE MOUNT INSTALLATION STEP 2 (REMOVE CAP FOR DIP-SWITCH SETTINGS)

**Step 3:** Please refer to *DIP-switch and LEDs* on page 21 for correct DIP-switch settings.



**FIGURE 8: POLE MOUNT INSTALLATION STEP 3 (DIP-SWITCH AND LEDs)**

**Step 4:** Locate an appropriate location for the pole mount installation. See drawings under step 4 with respect to pole mount installation.

**IMPORTANT:** Make sure that there are no magnetic disturbances (see *Mounting and installation considerations* on page 5 for details) or compass within 0.3 m. (1 ft.) of the LT-1000 NRU. Mount the LT-1000 NRU at least 1 m. away from VHF, UHF, MF-HF, Inmarsat, Iridium, etc. radio transmitting equipment. Make sure that the LT-1000 NRU minimum has a 20 degree angle towards a radar antenna (above or below).

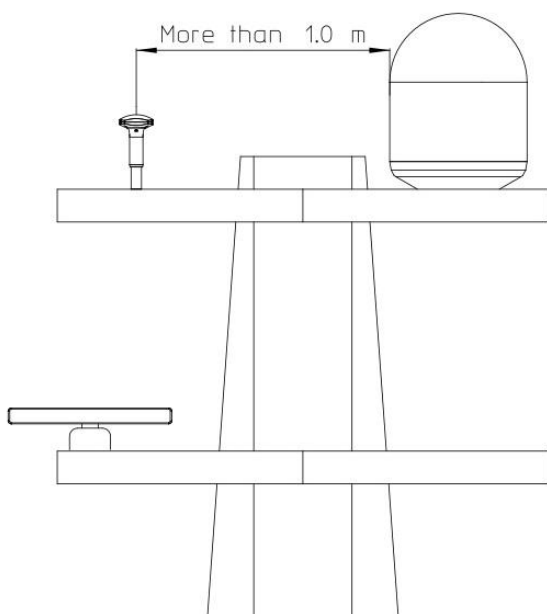

**FIGURE 10: POLE MOUNT INSTALLATION STEP 4 (LOCATE AN APPROPRIATE LOCATION)**

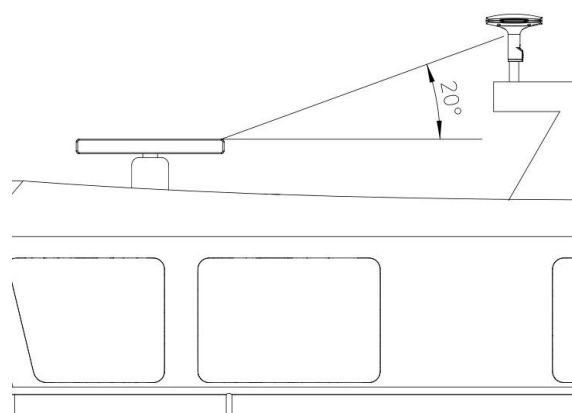

**FIGURE 9: POLE MOUNT INSTALLATION STEP 4 (LOCATE AN APPROPRIATE LOCATION)**



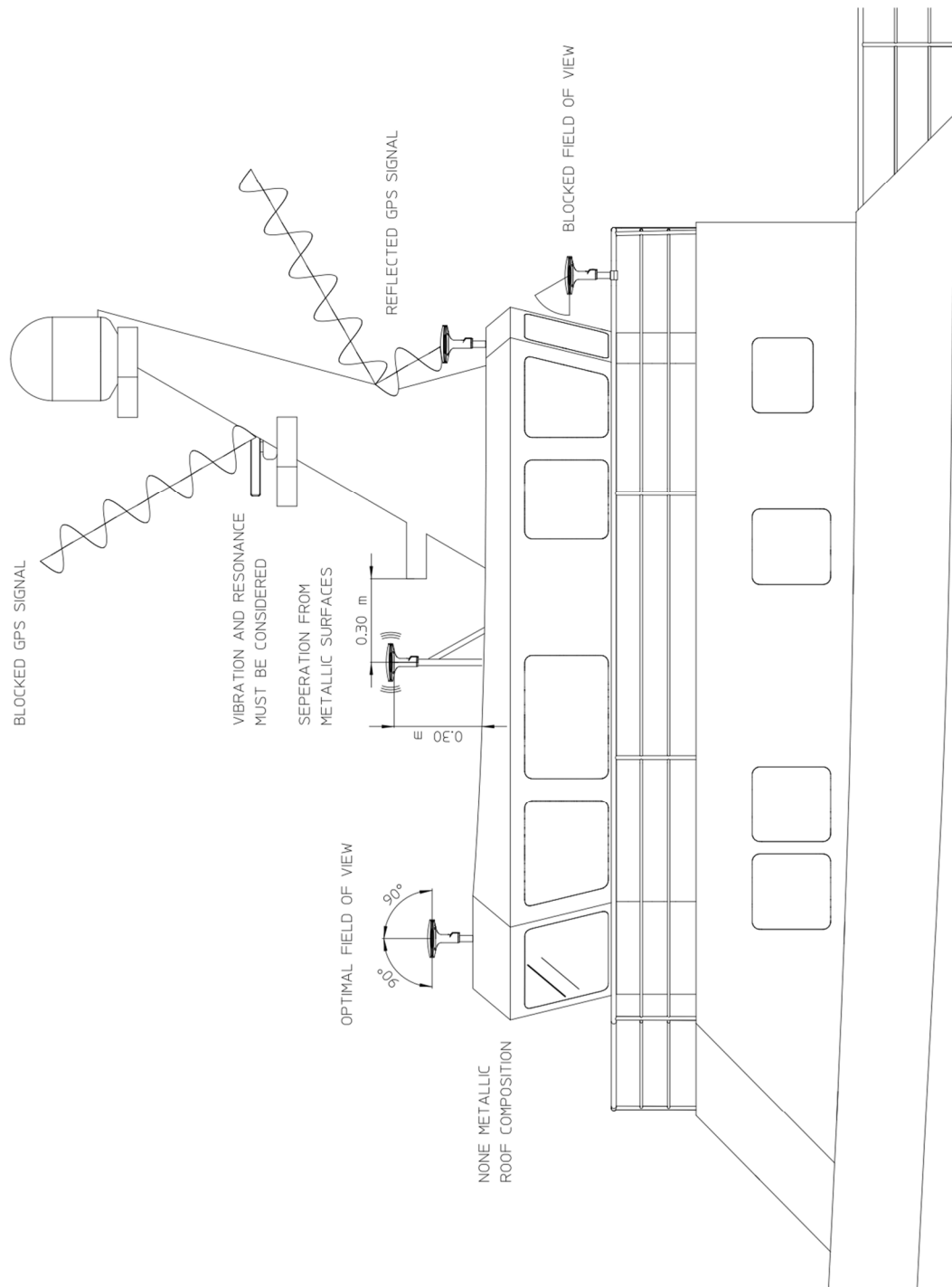
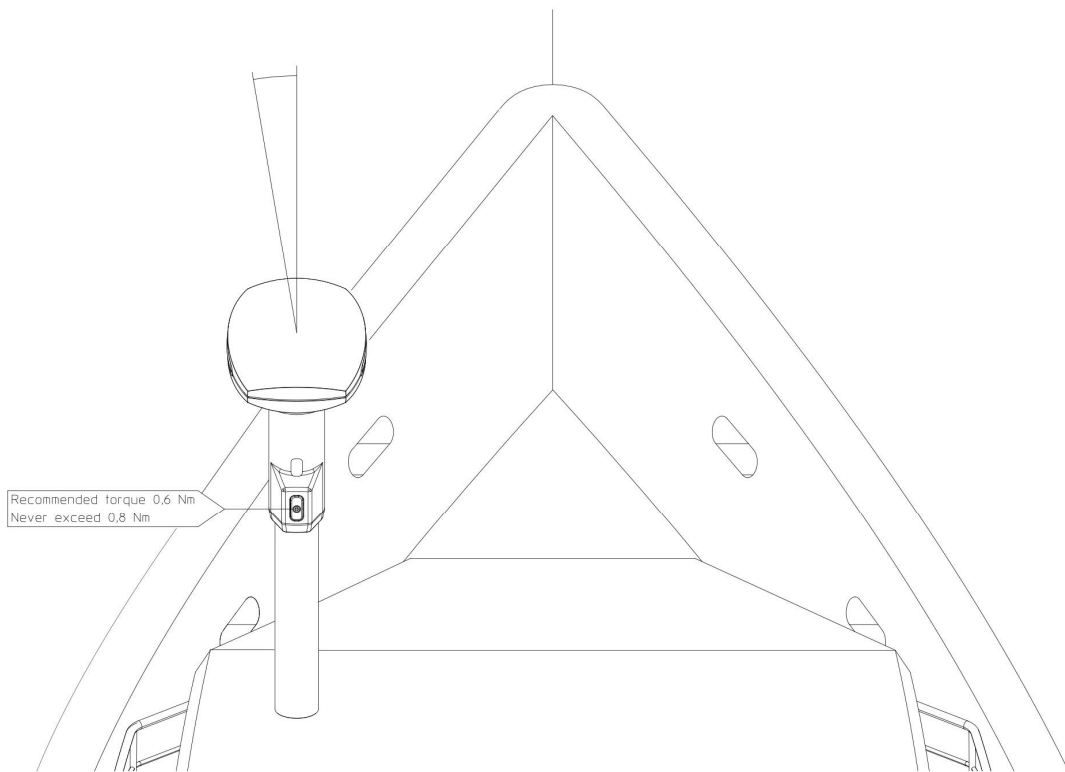
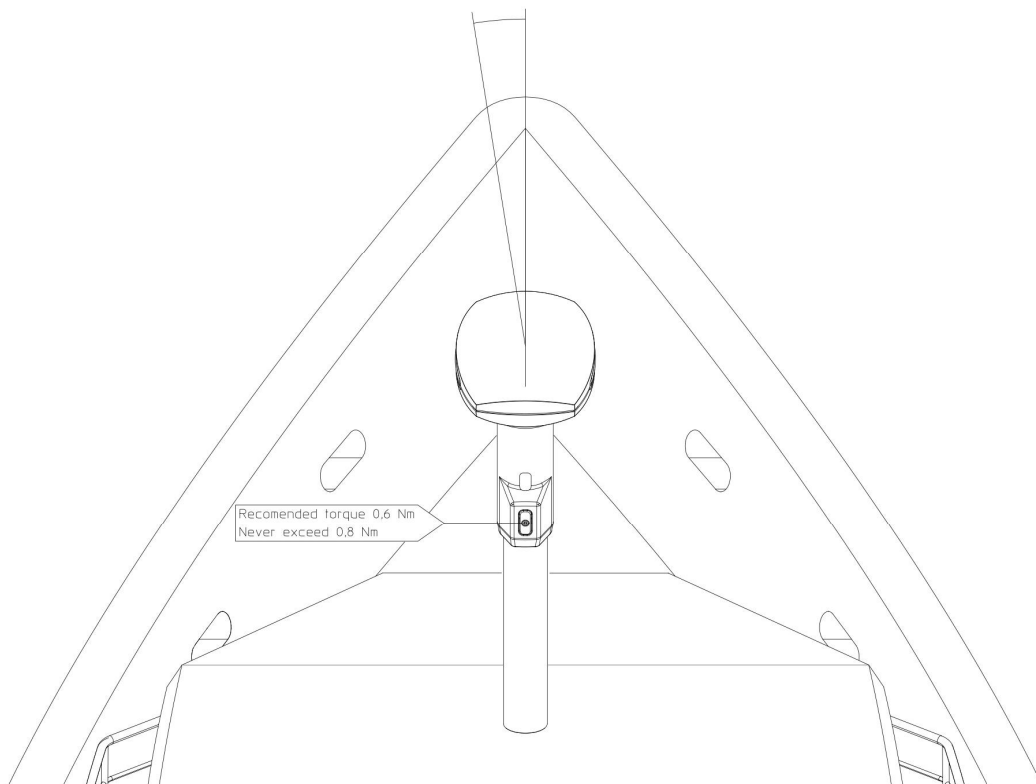

FIGURE 11: POLE MOUNT INSTALLATION STEP 4 (LOCATE AN APPROPRIATE LOCATION)

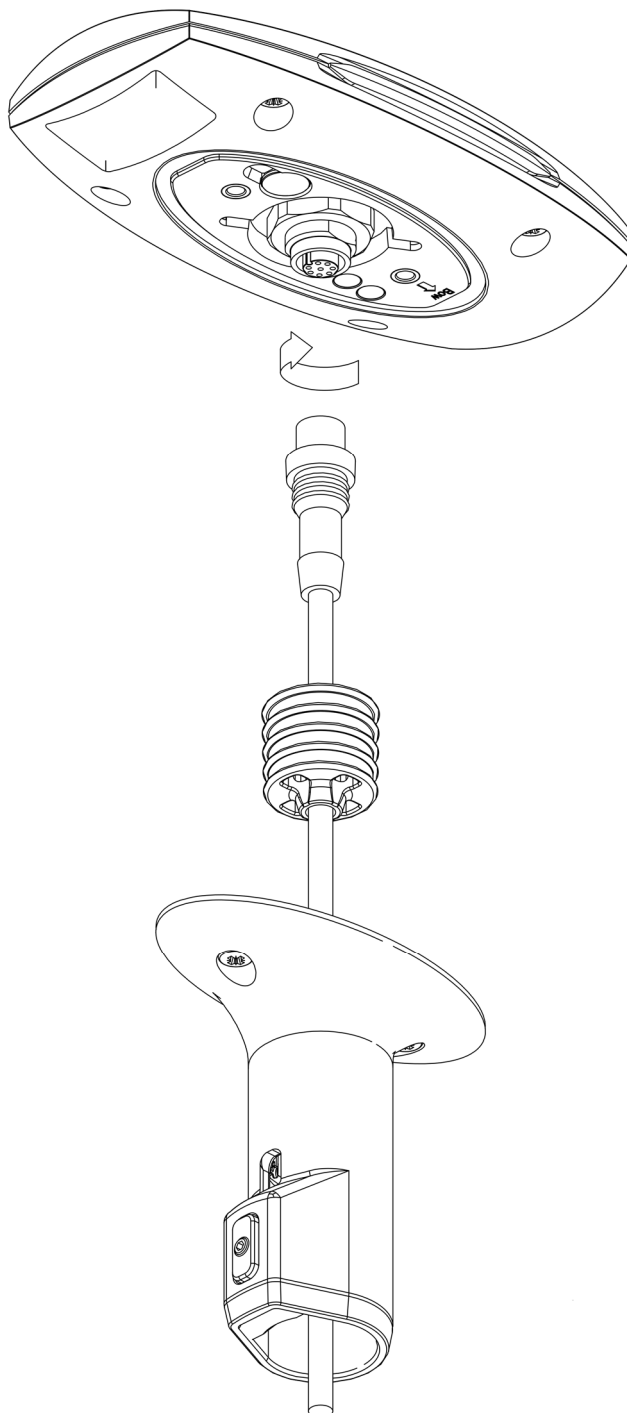

**FIGURE 12: POLE MOUNT INSTALLATION STEP 4 (LOCATE AN APPROPRIATE LOCATION)**

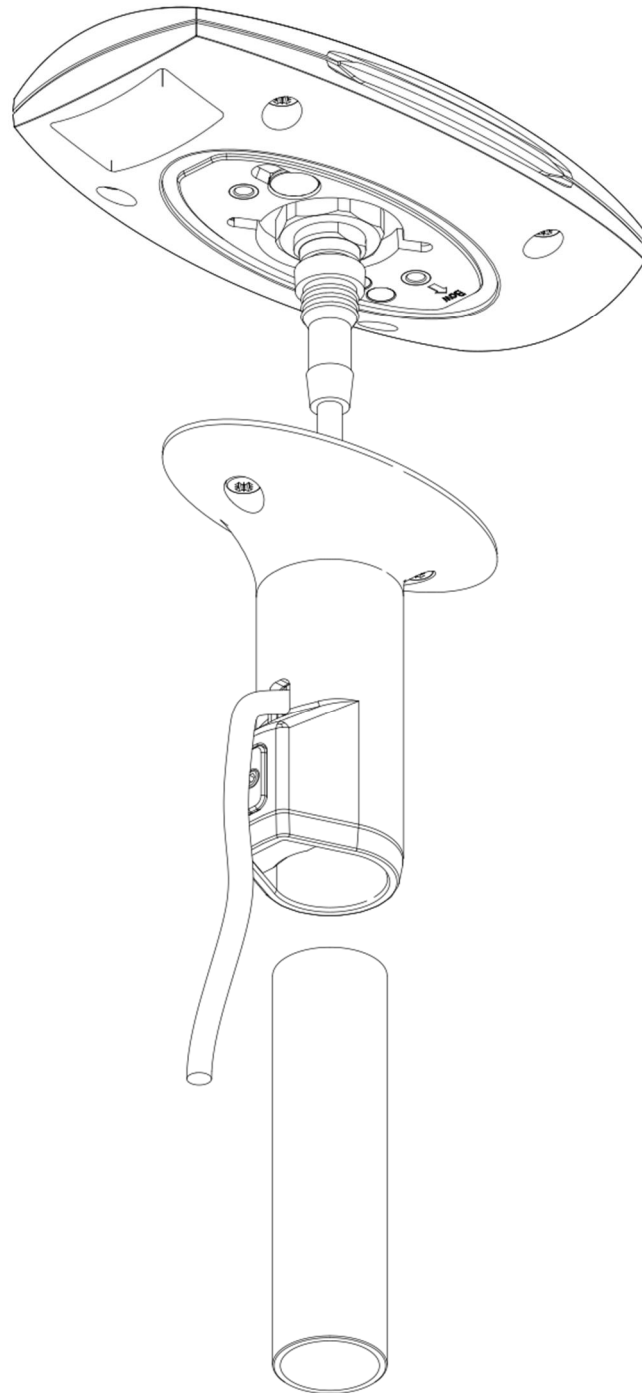

**FIGURE 13: POLE MOUNT INSTALLATION STEP 4 (LOCATE AN APPROPRIATE LOCATION)**

**Step 5:** Complete the internal or external cable routing. Feed the communication cable through the pole mount and install the cable plug.

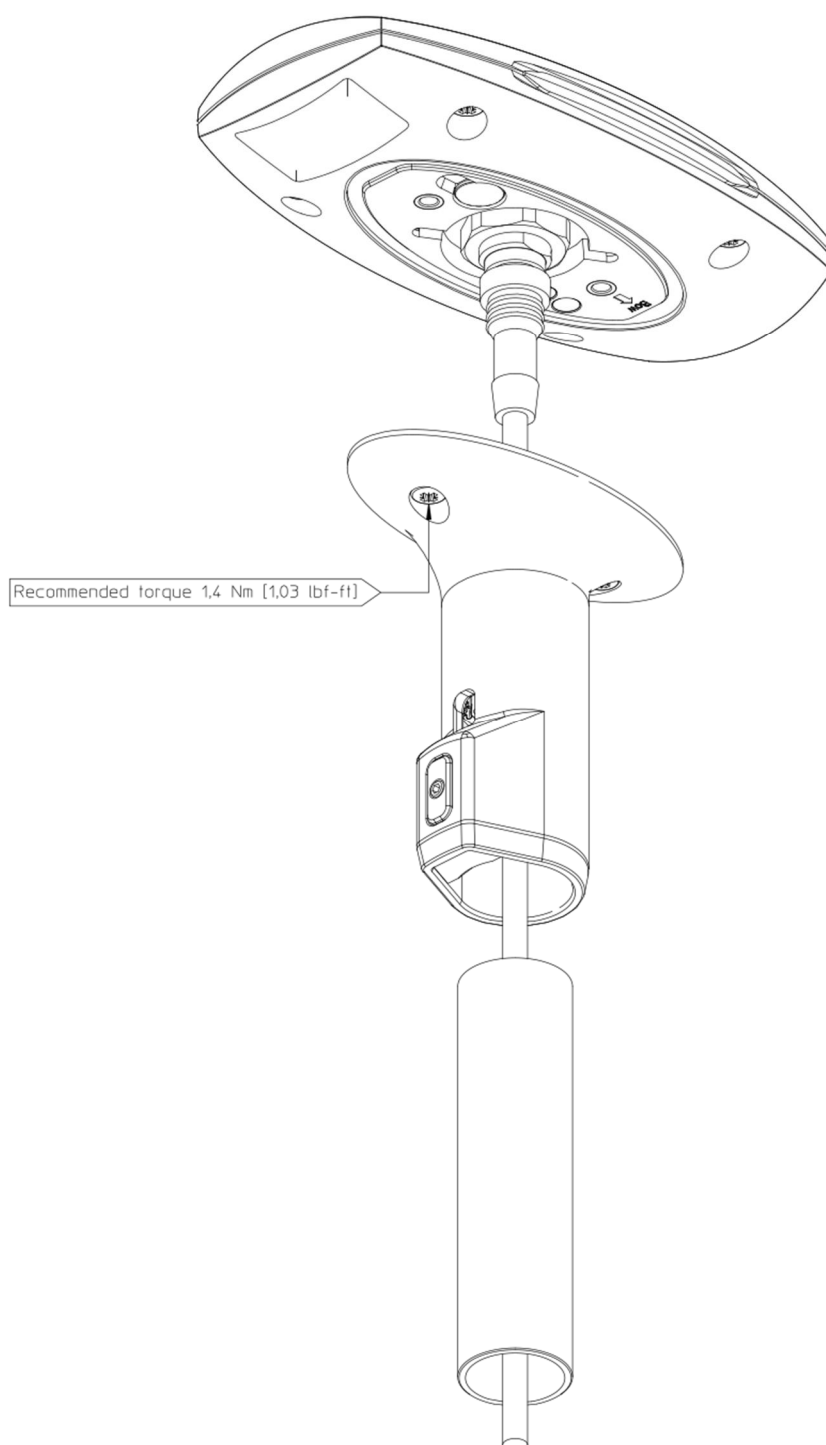

**FIGURE 14: POLE MOUNT INSTALLATION STEP 5 (INTERNAL ROUTING OF THE COMMUNICATION CABLE)**



**FIGURE 15: POLE MOUNT INSTALLATION STEP 5 (EXTERNAL ROUTING OF THE COMMUNICATION CABLE)**

**Step 6:** Fasten the pole mount by securing the two stainless A4 screws onto the LT-1000 NRU as illustrated in Figure 16.

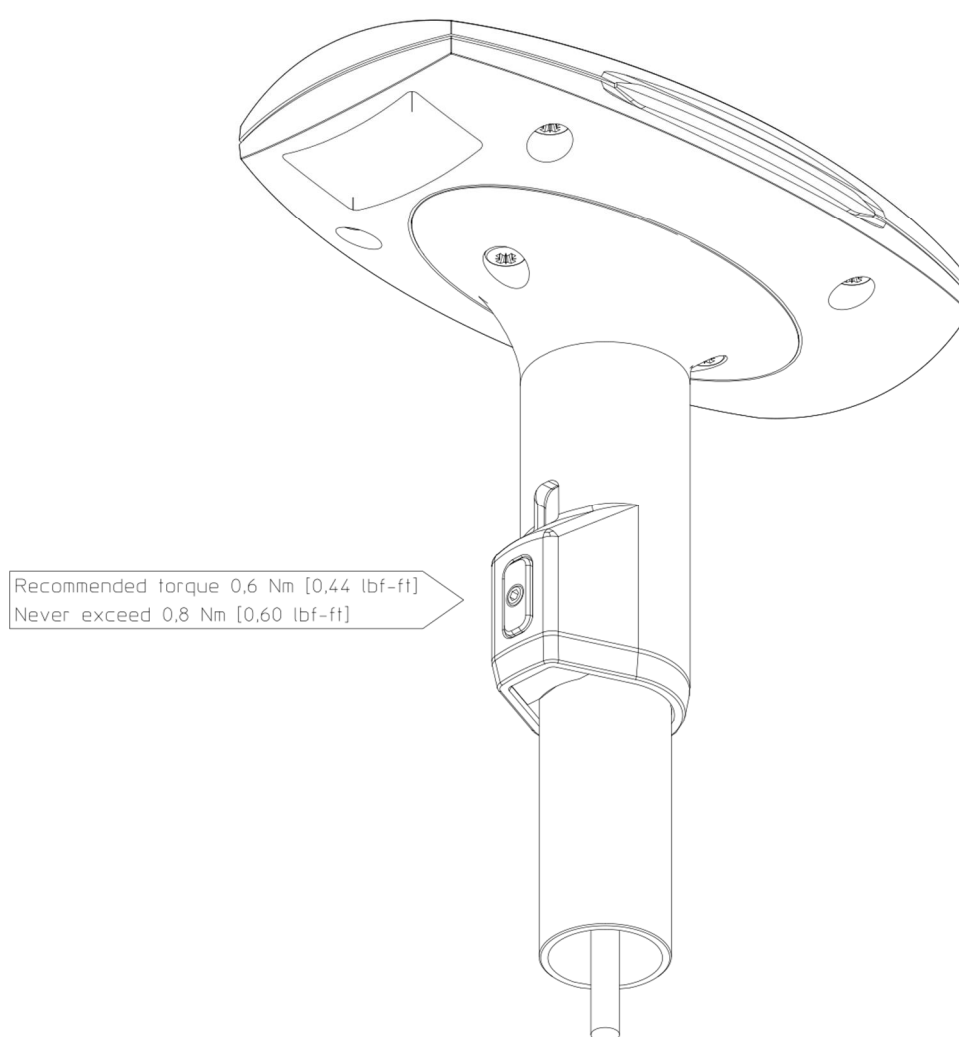

**FIGURE 16: POLE MOUNT INSTALLATION STEP 6 (SECURING THE TWO STAINLESS A4 SCREWS)**

**Step 7:** Adjust the heading direction of LT-1000 NRU before fastening the pinol screw in the pole mount.

**NOTE:** Final precision tuning of the Heading offset can be performed using the LT-service tool, see *Configuration using LT-Service Tool* on page 29.

**IMPORTANT:** The pinol screw used for fastening the pole mount shall not exceed 0.8 NM (0.6 lbs/ft).

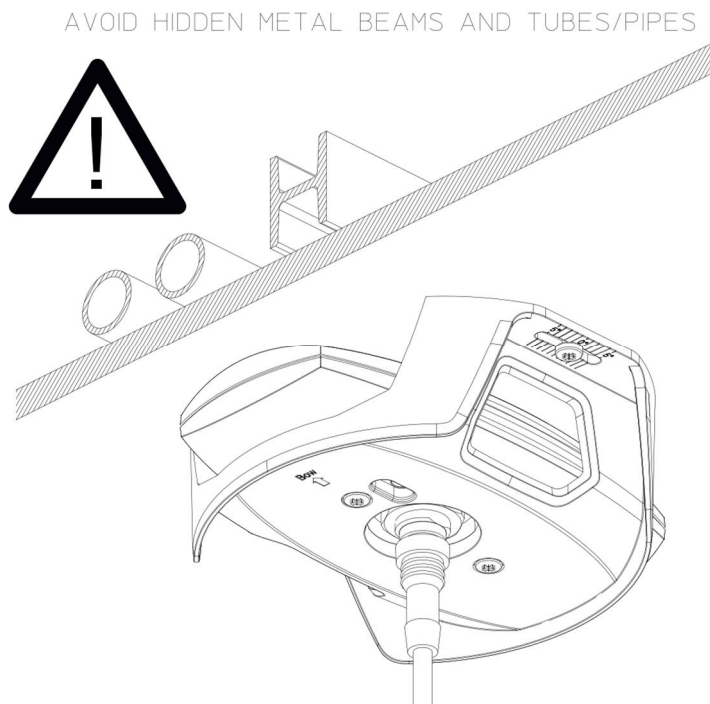

**FIGURE 17: POLE MOUNT INSTALLATION STEP 7 (FASTENING THE PINOL SCREW IN THE POLE MOUNT)**

**Roof mount installation**

**Step 1:** Locate an appropriate location for the roof mount installation.

**IMPORTANT:** Make sure that there are no magnetic disturbances (see *Mounting and installation considerations* on page 5 for details) or compass within 30 cm / 1 ft. of the LT-1000 NRU.



**FIGURE 18: ROOF MOUNT INSTALLATION STEP 1 (LOCATE AN APPROPRIATE LOCATION)**

**Step 2:** Measure and mark the installation holes in accordance with the drawing. Use the enclosed two stainless A4 screws for mounting. It is possible to adjust heading with  $\pm 5$  degree before final clamping of the roof mount.

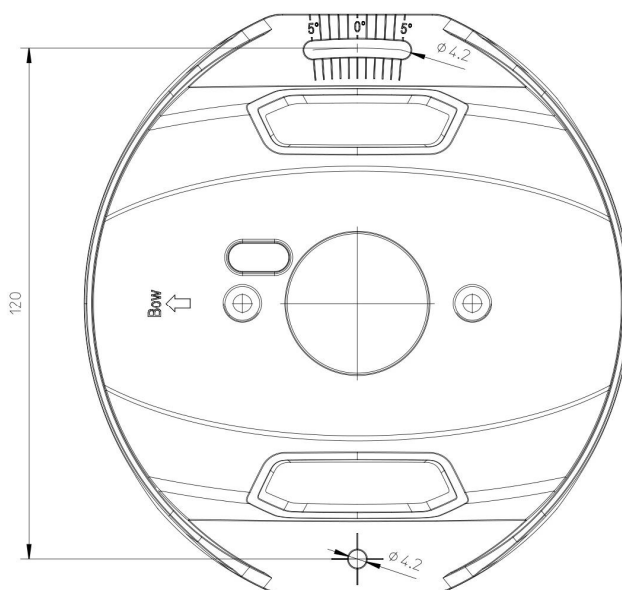

**FIGURE 19: ROOF MOUNT INSTALLATION STEP 2 (MEASURE AND MARK THE INSTALLATION HOLES)**

**Step 3:** Unpack the LT-1000 NRU and make a record of the unit serial number for support or warranty issues that could occur in the future.

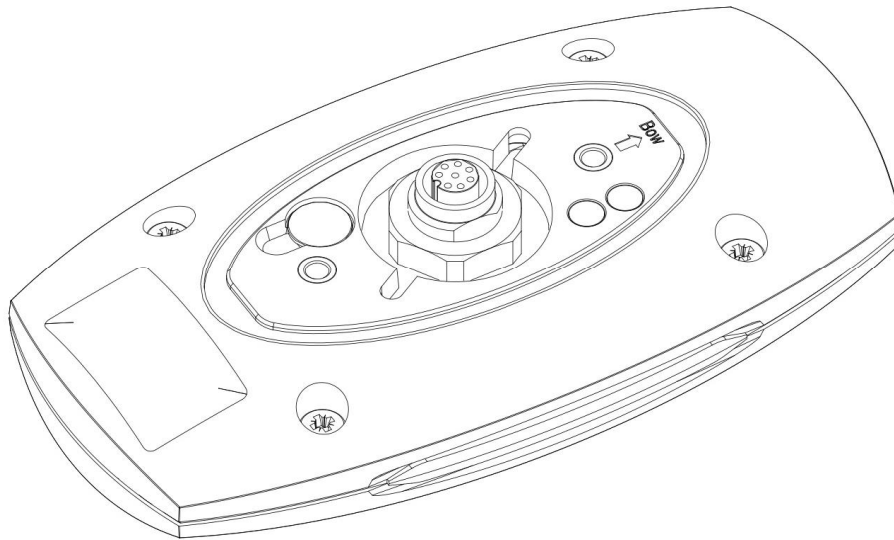

FIGURE 20: ROOF MOUNT INSTALLATION STEP 3 (BOTTOM SIDE OF THE LT-1000 NRU)

**Step 4:** Remove cap for DIP-switch setting. Remember to re-insert the cap after configuration of the DIP-switch.

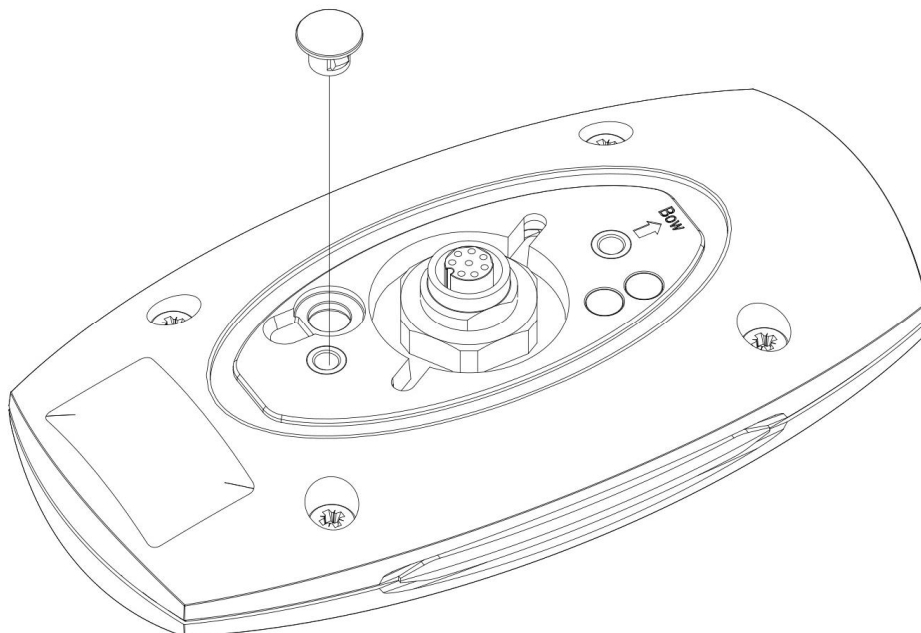
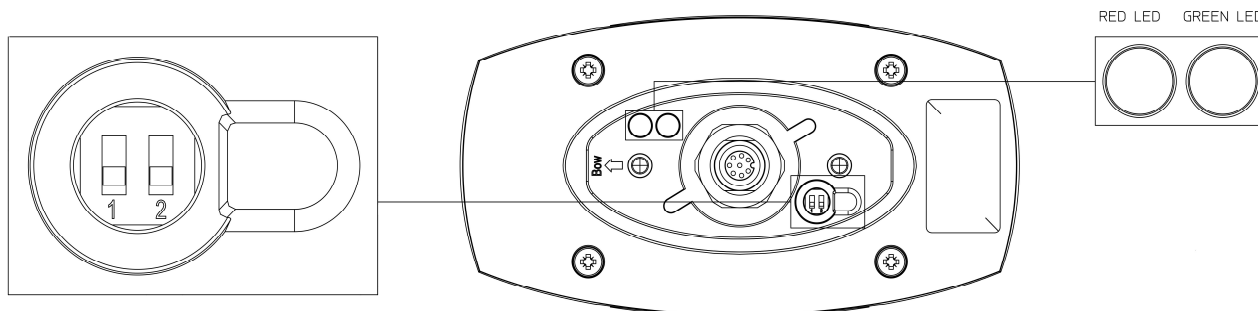

FIGURE 21: ROOF MOUNT INSTALLATION STEP 4 (REMOVE CAP FOR DIP-SWITCH SETTING)



**Step 5:** Please refer to *DIP-switch and LEDs* on page 21 for correct DIP-switch settings.



**FIGURE 22: ROOF MOUNT INSTALLATION STEP 5 (DIP-SWITCH AND LEDs)**

**Step 6:** Mount and secure the two stainless A4 screws (with securing disc) from the pole mount.

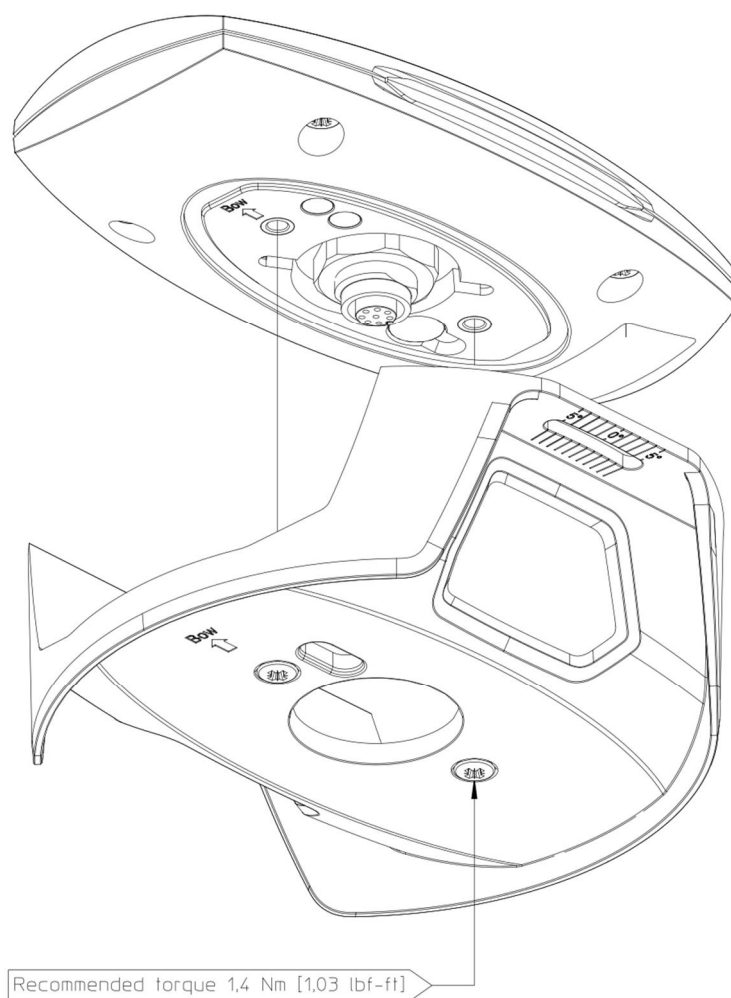

**FIGURE 23: ROOF MOUNT INSTALLATION STEP 6 (SECURE THE TWO STAINLESS A4 SCREWS)**

**Step 7:** Adjust the heading before final clamping of the two self-cutting stainless screws.

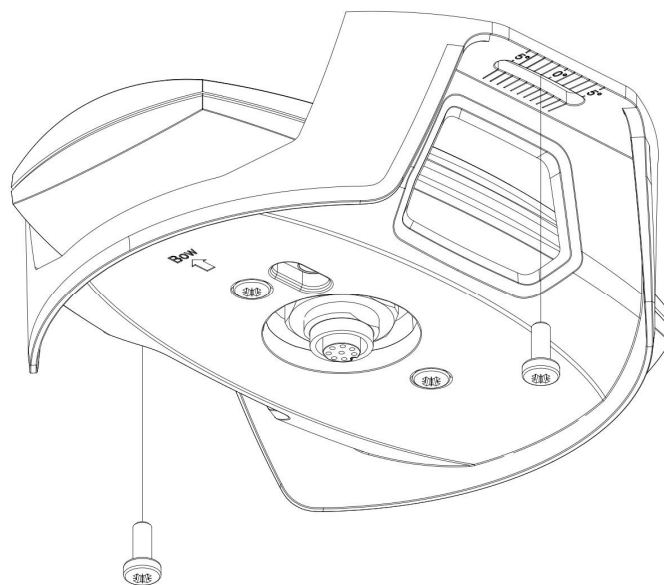

**FIGURE 24: ROOF MOUNT INSTALLATION STEP 7 (FINAL CLAMPING OF THE TWO SELF-CUTTING STAINLESS SCREWS)**

**Step 8:** Connect the communication cable.

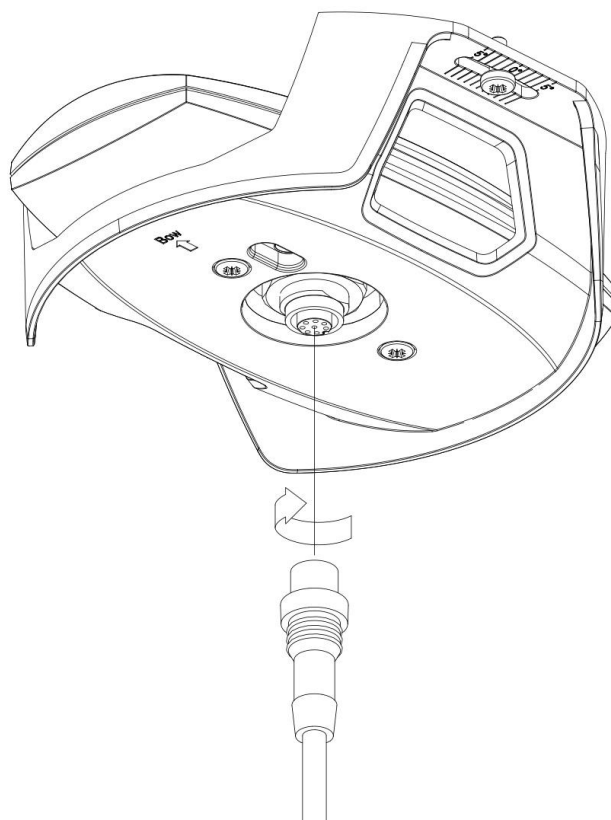

**FIGURE 25: ROOF MOUNT INSTALLATION STEP 8 (CONNECT THE COMMUNICATION CABLE)**

**Step 9:** Install the simple-cut end of the communication cable according to the details provided in *Connecting* on page 20.

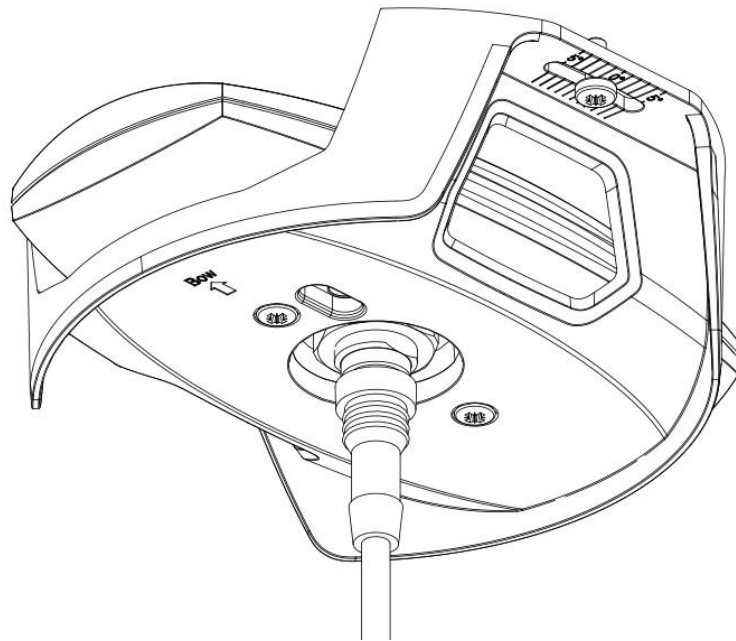

**FIGURE 26: ROOF MOUNT INSTALLATION STEP 9 (INSTALL THE SIMPLE-CUT END OF THE COMMUNICATION CABLE)**

## Connecting

This section provides relevant information for connecting the LT-1000 NRU to NMEA 0183, NMEA 2000, and the LT-Service Tool.

### Connector and cable definition

The LT-1000 NRU has an 8-pin M12 female connector, which is supporting simultaneously data on NMEA 0183 and NMEA 2000. The placement of the LT-1000 NRU connector is illustrated on Figure 27. A detailed connector pin out with pin numbering is illustrated in Figure 28.

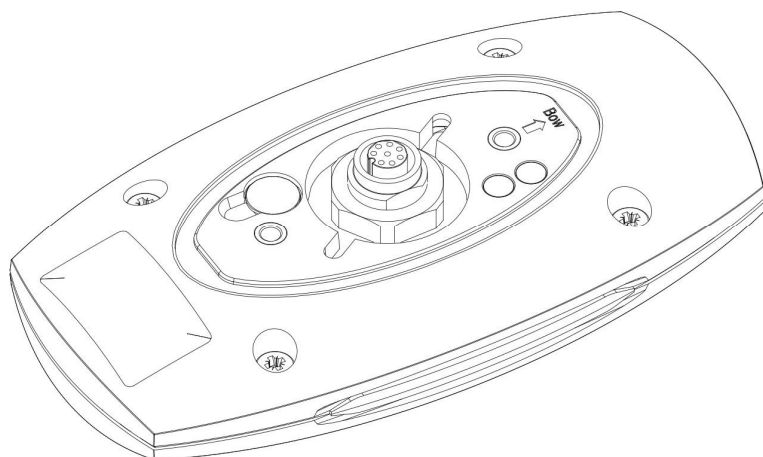

FIGURE 27: LT-1000 NRU (BOTTOM VIEW). 8-PIN M12 FEMALE CONNECTOR USED FOR CONNECTING THE LT-1000 NRU TO NMEA 0183, NMEA 2000, AND POWER.

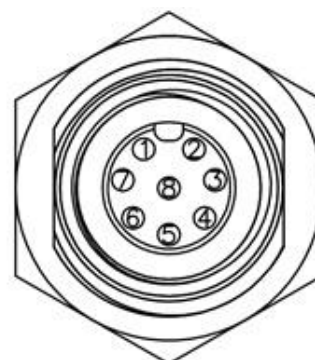

FIGURE 28: LT-1000 NRU CONNECTOR PIN NUMBERING

The LT-1000 NRU connector has a proprietary pin out and therefore a communication cable is always included in-the-box, see *Unpacking (in-the-box)* on page 5. The communication cable is available in two lengths: 10 or 30 meters. The LT-1000 NRU is delivered including a 10 meter cable (simple-cut). The communication cable color and connector pin assignment is illustrated in Table 3.

LT-1000 NRU Cable and Connector		
Pin No.	Cable Color	Connector Pin Assignment
1	Brown	TxD+
2	Yellow	TxD-
3	Black	GND
4	White	CAN_H
5	Blue	CAN_L
6	Orange	RxD-
7	Green	RxD+
8	Red	Vsupply

TABLE 3: COMMUNICATION CABLE COLOR AND LT-1000 NRU 8-PIN CONNECTOR PIN ASSIGNMENT.

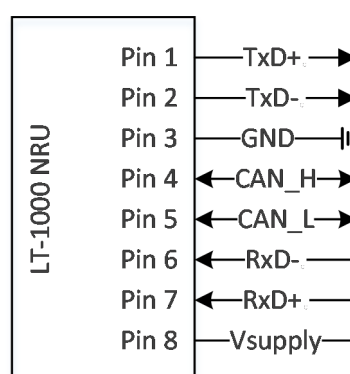

FIGURE 29: TRANSMIT AND RECEIVE DIRECTIONS FOR THE LT-1000 NRU.

**NOTE:** To avoid any misinterpretation, the transmit (Tx) and receive (Rx) directions are illustrated in Figure 29, relative to the LT-1000 NRU.

### DIP-switch and LEDs

The LT-1000 NRU has a built-in DIP-switch, which is accessible from the bottom side of the unit, before the pole or roof mount is mounted. To access the DIP-switch, the cap plug has to be removed; hereafter the installer will have direct access to configuration of the DIP-switch. Furthermore, two LEDs are available on the bottom side of the LT-1000 NRU. The placement of the DIP-switch and LEDs are illustrated in Figure 30.

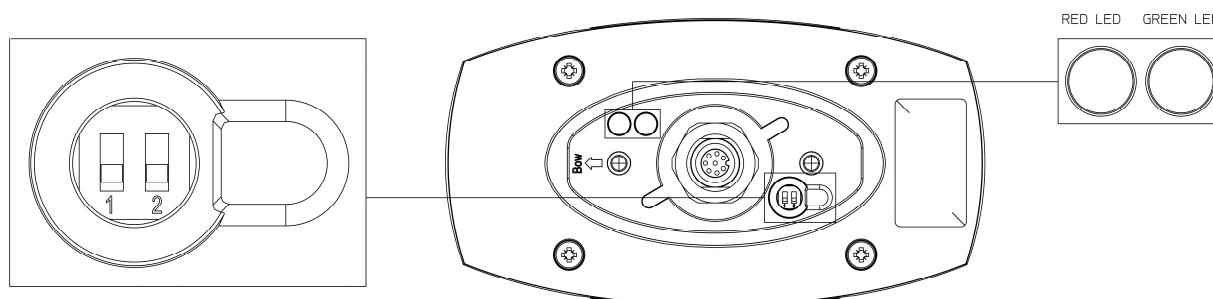

FIGURE 30: LT-1000 NRU DIP-SWITCH AND LEDs (BOTTEM SIDE OF LT-1000 NRU).

The configuration of the DIP-switch is illustrated in Figure 31.

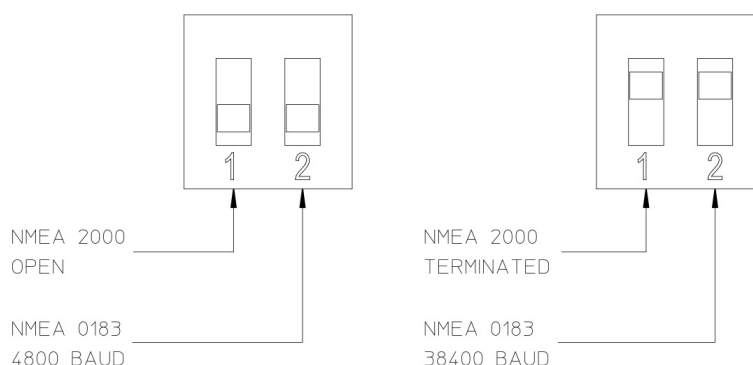

FIGURE 31: DIP-SWITCH CONFIGURATION (NMEA 0183 BAUD RATE AND NMEA 2000 OPEN OR TERMINATED)

**IMPORTANT:** The DIP-switch is configured to 4.800 baud (NMEA 0183) and ‘Open’ (NMEA 2000) when leaving the factory. However, the installer should always check the settings of the DIP-switch prior to an installation. Make sure to hold the LT-1000 NRU as illustrated on Figure 30, when reading and configuring the DIP-switch, to avoid wrong settings.

The color code and description of the LEDs are illustrated in Table 4.

LT-1000 NRU LEDs Color Description		
Green LED	Red LED	Description
On	Off	Power on unit. Unit is ready for navigation.
On	On	Power on Unit. Error or warnings present. Check installation setup and <i>Troubleshooting</i> on page 33 to resolve the problem. Connect the LT-Service Tool to read-out details from the LT-1000 NRU, see <i>Connecting LT-Service Tool</i> on page 25.
Off	NA	No power on unit.

TABLE 4: LT-1000 NRU LED COLOR CODE AND DESCRIPTION

### Connecting to NMEA 0183

If connecting the LT-1000 NRU to a NMEA 0183 device, then it is only required to connect the transmit part of the NMEA 0183 wires TxD+ (Brown) and TxD- (Yellow) from the communication cable.

**NOTE:** Make sure that the LT-1000 NRU is configured for the desired baud rate (4800 or 38400 baud), see *DIP-switch and LEDs* on page 21. Check that both the NMEA 0183 receive device and the LT-1000 NRU have the same GND reference, as illustrated in Figure 32 and Figure 33.

**IMPORTANT:** It is recommended to connect the LT-1000 NRU with a balanced NMEA 0183 connection (RS-422) as illustrated in Figure 32. An unbalanced connection (RS-232), as illustrated in Figure 33, is less robust and should only be considered when using a short communication cable.

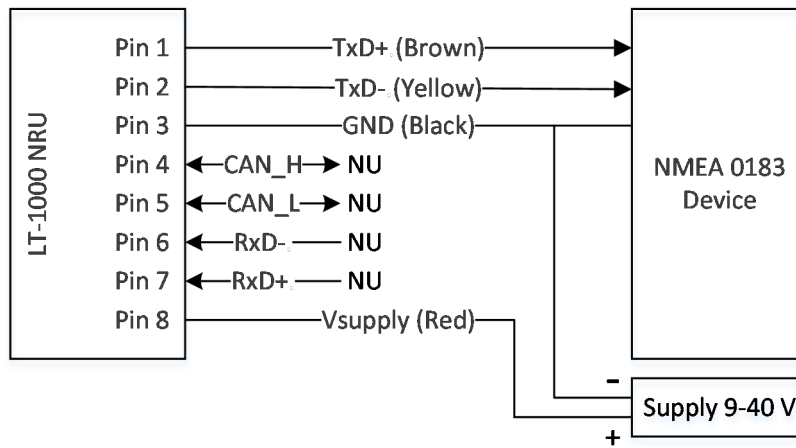

FIGURE 32: CONNECTING THE LT-1000 NRU TO A BALANCED NMEA 0183 DEVICE.

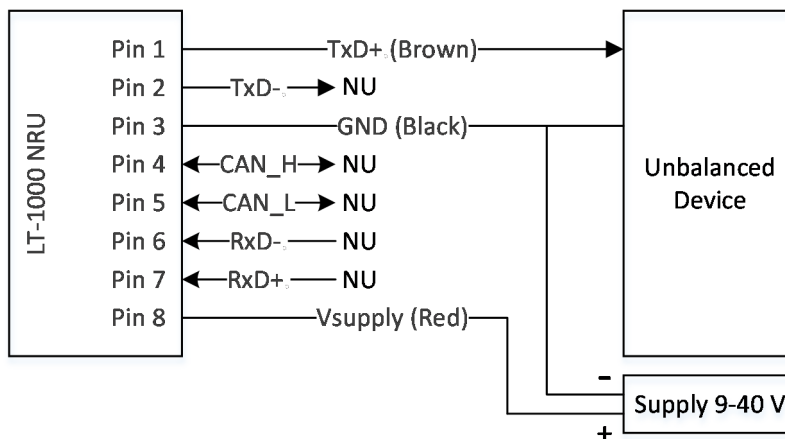

FIGURE 33: CONNECTING THE LT-1000 NRU TO AN UNBALANCED DEVICE.

### Connecting to NMEA 2000

If connecting the LT-1000 NRU to a NMEA 2000 network (i.e. backbone) then it is required to use a screw-in connector as illustrated in Figure 34. The screw-in connector is in-the-box together with the LT-1000 NRU.

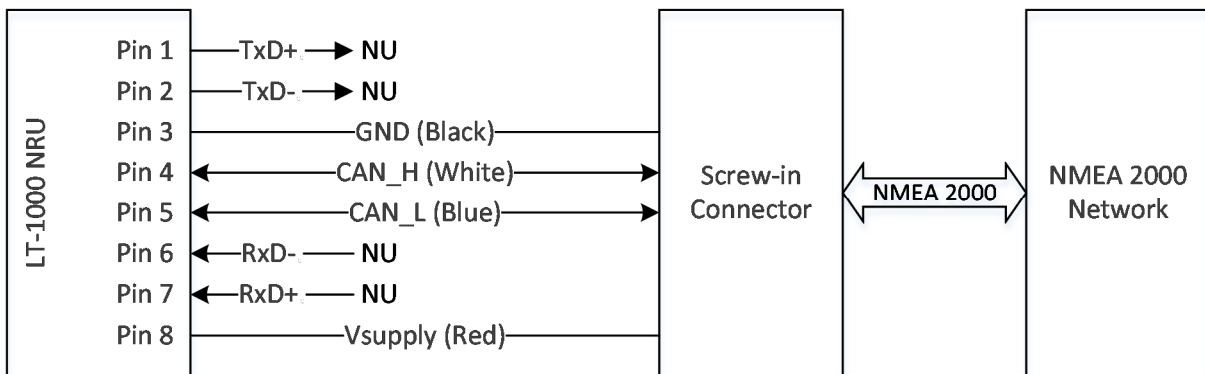

FIGURE 34: CONNECTING THE LT-1000 NRU TO A NMEA 2000 BACKBONE. A SCREW-IN CONNECTOR IS REQUIRED FOR CONNECTING THE LT-1000 NRU TO A NMEA 2000 NETWORK.

**NOTE:** The screw-in connector is connected to the communication cable by cutting the cable in the right length, stripping the wires, screwing the specific wires to the connector, and then re-assemble the connector again.

The screw-in connector outline is illustrated in Figure 35. The pin-out and numbering of the screw-in connector is illustrated on Figure 36, while the wiring details for interconnection with the communication cable is shown in Table 5.

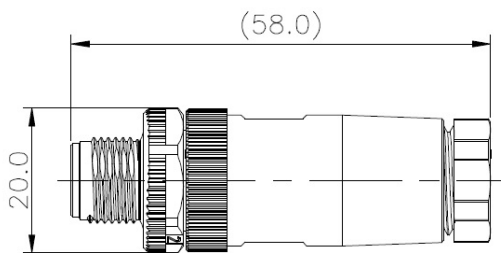

FIGURE 35: NMEA 2000 SCREW-IN CONNECTOR (M) OUTLINE

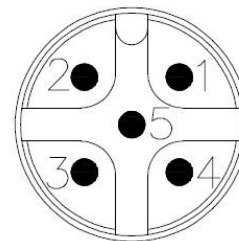

FIGURE 36: NMEA 2000 SCREW-IN CONNECTOR PIN NO.

NMEA 2000 Screw-in Conn. Wiring		
LT-1000 Cable Color	LT-1000 Cable Designation	Screw-in Conn. Pin No.
-	-	1
Red	Vsupply	2
Black	GND	3
White	CAN_H	4
Blue	CAN_L	5

TABLE 5: ILLUSTRATES HOW THE LT-1000 NRU 8-PIN MULTI CABLE IS CONNECTED TO A NMEA 2000 SCREW-IN CONNECTOR.

**NOTE:** The LT-1000 does not require a connection on Pin No. 1: drain/shield. The unit is designed to work with open cable shield.

**NOTE:** There are two possibilities for the LT-1000 NRU to be connected to an NMEA 2000 network: ‘Open’ or ‘Terminated’. A DIP-switch in the LT-1000 NRU shall be configured depending on the installation. The default setting for the DIP-switch is ‘Open’, but shall always be verified prior to an installation. The DIP-switch settings are described in *DIP-switch and LEDs* on page 21.

The remaining figures in this sub-chapter does not show the screw-in connector for simplicity.

### NMEA 2000 Installation

The LT-1000 NRU can be configured to ‘Open’ or ‘Terminated’. The LT-1000 NRU is delivered with a NMEA 2000 screw-in connector, which is used to interconnect the communication cable to a NMEA 2000 backbone. The Dip-switch on the LT-1000 NRU can be configured to either ‘Open’ or ‘Terminated’, see *DIP-switch and LEDs* on page 21 (factory default: ‘Open’). Figure 37 and Figure 38 are illustrating two options for connecting the LT-1000 NRU to a NMEA 2000 network (backbone).

#### NMEA 2000 (‘Open’)

If the LT-1000 NRU is installed as illustrated in Figure 37, then the DIP-switch must be configured to ‘Open’. For correct configuration of the DIP-switch, see *DIP-switch and LEDs* on page 21. The LT-1000 NRU is connected to the NMEA 2000 backbone using a drop-cable.

**NOTE:** Make sure that the communication cable, delivered together with the LT-1000 NRU, is shortened to a maximum length of 6 meters as defined in the NMEA 2000 standard for a drop cable.

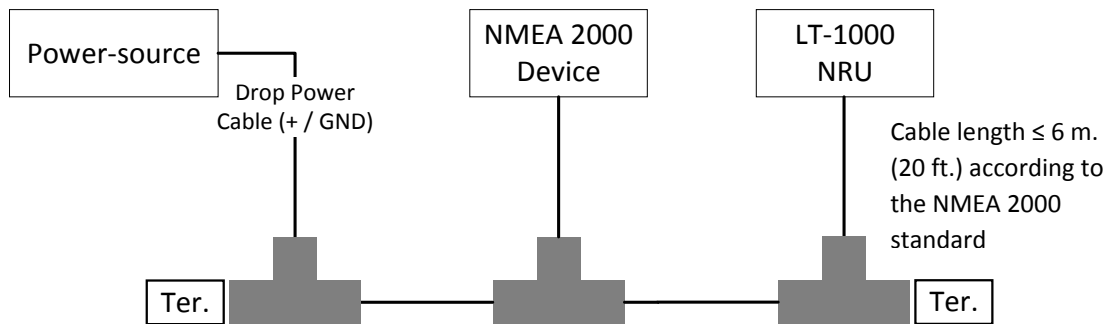

FIGURE 37: LT-1000 NRU CONNECTED TO A NMEA 2000 BACKBONE WITH THE DIP-SWITCH CONFIGURED TO ‘OPEN’. THE NMEA 2000 SCREW-IN CONNECTOR IS NOT ILLUSTRATED IN THIS FIGURE.

#### NMEA 2000 (‘Terminated’)

If the LT-1000 NRU is installed as illustrated in Figure 38, then the DIP-switch must be configured to ‘Terminated’. For correct configuration of the DIP-switch, see *DIP-switch and LEDs* on page 21 (factory default: ‘Open’). The LT-1000 NRU is connected to the NMEA 2000 using a standard backbone cable.

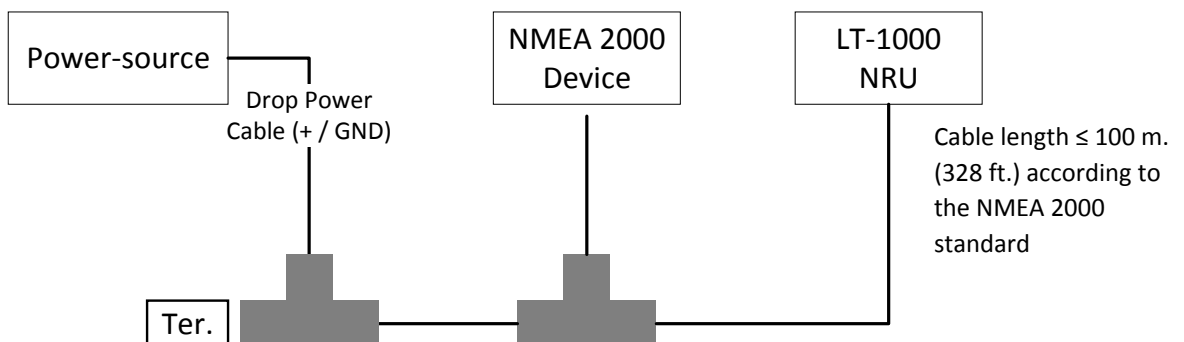

FIGURE 38: LT-1000 NRU CONNECTED TO A NMEA 2000 BACKBONE WITH THE DIP-SWITCH CONFIGURED TO ‘TERMINATED’. THE NMEA 2000 SCREW-IN CONNECTOR IS NOT ILLUSTRATED IN THIS FIGURE.

Details on how to connect the communication cable with the NMEA 2000 screw-in connector, see *Connecting to NMEA 2000* on page 23.



### Connecting LT-Service Tool

The LT-Service Tool is a PC program made for configuration, maintenance, and service purposes of the LT-1000 NRU. The LT-Service Tool is an optional program to use. For details and functionality, see *Configuration using LT-Service Tool* on page 29. This sub-chapter is describing how to physically interconnect a PC (with the LT-Service Tool), to a LT-1000 NRU. The LT-Service Tool is using the NMEA 0183 interface for communicating with the LT-1000 NRU (both Tx and Rx directions).

Use either a ‘USB to RS-422 converter’ or connect a serial port directly to the LT-1000 NRU as described in the following sub-sections. The LT-1000 NRU requires an input voltage of 9-40 VDC. Most of the USB to RS-422 converter’s and serial interfaces are only providing 5 VDC. Make sure that GND on both devices (PC and LT-1000 NRU) are connected to the same reference.

**NOTE:** The LT-Service Tool will automatically detect all LT-Navigation devices, which are connected to the PC’s peripheral interfaces (USB and serial). Make sure that Tx and Rx wires are connected correctly. The LT-Service Tool will automatically try both 4.800 and 38.400 baud to search for possible LT-Navigation devices. If the LT-Service Tool does not automatically detects any LT-Navigation devices, see *Configuration using LT-Service Tool* on page 29, where both automatically and manual connection modes are described.

### USB to RS-422 converter

A standard USB to RS-422 converter, as illustrated in Figure 39, is perfect for providing a communication link in between the LT-Service Tool and the LT-1000 NRU. The PC is connected to the ‘USB to RS-422 converter’ through a standard USB cable.

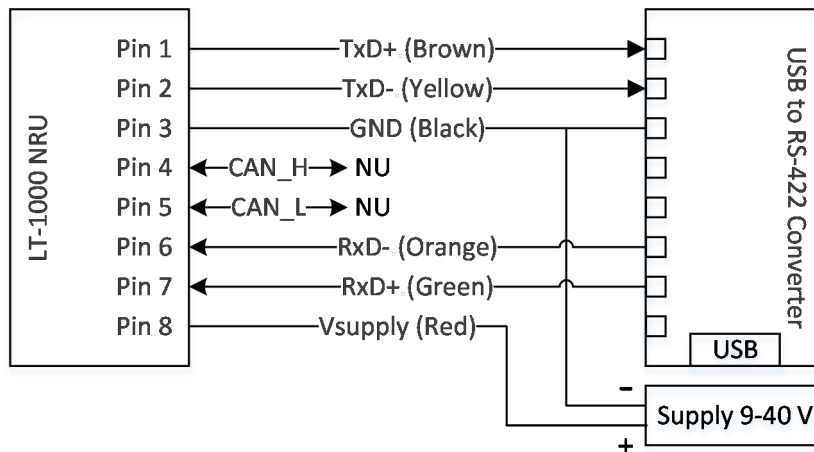

FIGURE 39: USB TO RS-422 CONVERTER PROVIDING THE COMMUNICATION LINK IN BETWEEN THE PC (LT-SERVICE TOOL) AND THE LT-1000 NRU.

**NOTE:** Windows may wrongfully recognize an USB to Serial device, as a mouse, if the device is transmitting when being plugged into the PC. Avoid this by giving Windows time to recognize the USB to Serial device before powering on the LT-1000 NRU.

### Serial Port (RS-422)

Illustration of a RS-422 interface in between a serial port and the LT-1000 NRU for providing a communication link for the LT-Service Tool, see Figure 40. The RS-422 interface is balanced and more robust than an unbalanced serial interface, which is illustrated in Figure 41.

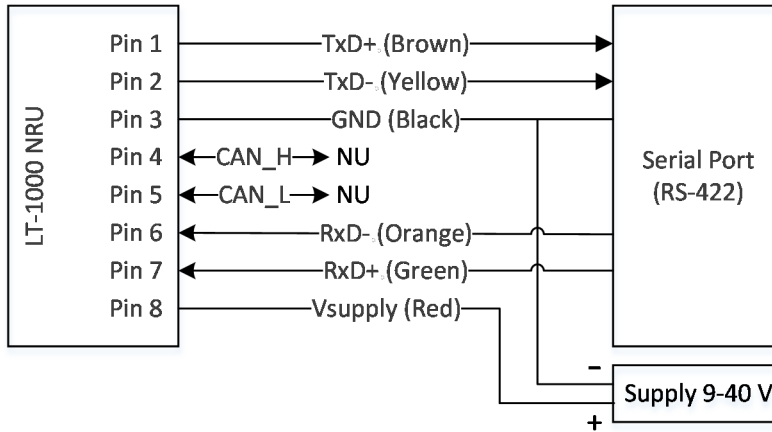

FIGURE 40: RS-422 (BALANCED) SERIAL INTERFACE PROVIDING THE COMMUNICATION LINK IN BETWEEN THE LT-SERVICE TOOL AND THE LT-1000 NRU.

**NOTE:** The RS-422 interface is using both Tx and Rx transmission lines (balanced/differential) and is therefore a more robust communication link than the RS-232 interface. The LT-1000 NRU is supporting both RS-422 and RS-232 communicating link to the LT-Service Tool.

### Serial port (RS-232)

Illustration of a RS-232 interface in between a serial port and the LT-1000 NRU for providing a communication link for the LT-Service Tool, see Figure 41.

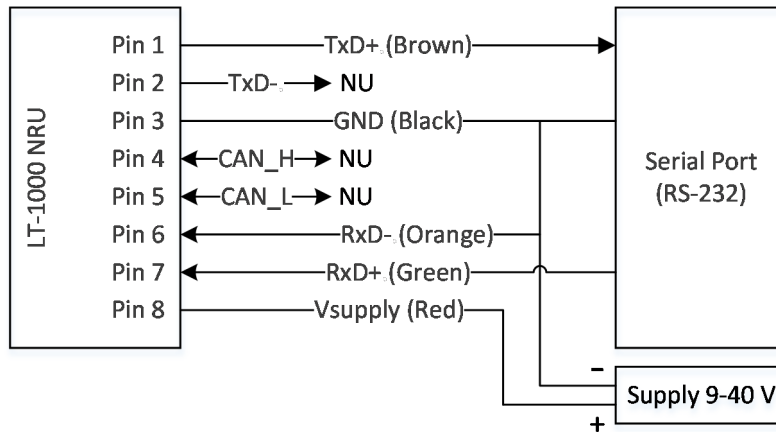

FIGURE 41: RS-232 (UNBALANCED) SERIAL INTERFACE PROVIDING THE COMMUNICATION LINK IN BETWEEN THE LT-SERVICE TOOL AND THE LT-1000 NRU

**NOTE:** When using the RS-232 (unbalanced) serial communication link, it is important that the RxD+ signal level from the serial port is > 5 VDC for proper operation.

### Deviation calibration

The magnetometer sensors in the LT-1000 NRU may be affected by magnetic disturbances from the vessel, which needs to be corrected in order to deliver magnetic heading (and thus true heading). The source of these magnetic disturbances could be, but not limited to; engines, power cables, etc. This discrepancy between magnetic and compass heading is called the “deviation”.

Deviation will cause incorrect heading data if not corrected. To compensate for deviation, it is necessary to complete a deviation calibration of the magnetometers, after installation of the LT-1000 NRU.

**IMPORTANT:** The LT-1000 NRU will indicate absence of a valid calibration by outputting heading (true and magnetic) with a 5 degrees resolution. When a calibration has been successful, the heading will be output with full resolution.

### Calibration pattern

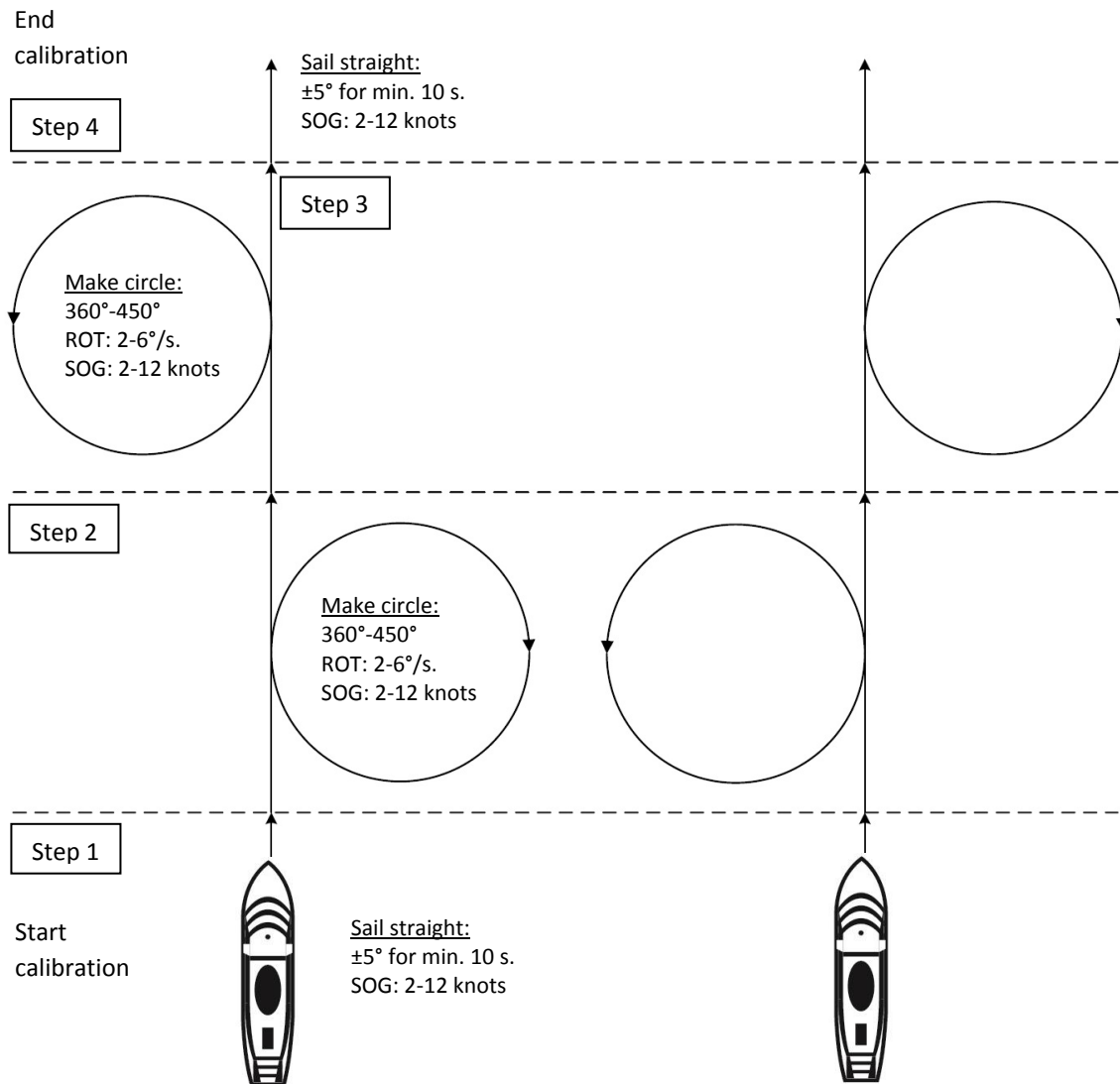

FIGURE 42: DEVIATION CALIBRATION FOR THE LT-1000 NRU (OPTION 1 OR 2)

### Calibration procedure

After completed installation, and before configuration of the LT-1000 NRU heading offset, it is required to perform a deviation calibration. The calibration must be performed in open and calm waters, and will determine the ship's influence on the magnetic sensors.

The LT-1000 NRU will automatically perform a calibration when it detects the vessel is sailing a specific pattern. To trigger a calibration, guide the vessel through the patterns (option 1 or 2), which are illustrated in Figure 42.

**NOTE:** The best result is achieved at low speed (SOG), low rate of turn (ROT) and in calm waters.

#### Procedure (step by step):

- Step 1: Keep a steady course ( $\pm 5$  degrees) for minimum 10 seconds  
SOG: 2–12 knots
- Step 2: Make a full circle (360-450°) clockwise or counterclockwise  
ROT: 2-6 degrees/second (1 -3 minutes pr. circle)  
SOG: 2-12 knots
- Step 3: Make a full circle (360-450°) in opposite direction  
ROT: 2-6 degrees/second (1 -3 minutes pr. circle)  
SOG: 2-12 knots
- Step 4: Keep a steady course ( $\pm 5$  degrees) for minimum 10 seconds  
SOG: 2–12 knots

If the calibration fails, please repeat step 1 to 4 again.

**NOTE:** In order to get the best possible heading accuracy on the LT-1000 NRU, it is required to compensate for the heading mounting offset. The LT-Service Tool is supporting this functionality, see *Configuration using LT-Service Tool* on page 29 and *Mounting offset adjustment* on page 31.

**IMPORTANT:** If the LT-1000 NRU is physically moved or rotated, it is required to perform a new calibration. Otherwise, the deviation calibration will not be valid.

**NOTE:** In order to verify that a subsequent deviation calibration has succeeded, see *Verify a subsequent deviation calibration* on page 31.

## Configuration using LT-Service Tool

The LT-Service Tool is a PC program interfacing and communicating with LT-Navigation devices. The LT-Service Tool is communicating via the NMEA 0183 serial interface. The newest available LT-Service Tool will be available from the local dealer or distributor, see [www.thrane.eu](http://www.thrane.eu) (Dealers & Distributors).

File name: LT-Service\_vX.XX.exe

**NOTE:** The LT-Service Tool is an optional PC program, which can be used together with the LT-1000 NRU. It is possible to install the LT-1000 NRU and use it for navigational purposes, without configuration by the LT-Service Tool. The LT-Service Tool is intended for installation and service by trained personnel.



FIGURE 43: THE LT-SERVICE TOOL WILL AUTOMATICALLY SEARCH FOR LT-NAVIGATION DEVICES, WHICH ARE CONNECTED TO THE PC. A MANUAL CONNECTION MODE IS ALSO AVAILABLE.

### Identify a LT-Navigation device

The LT-Service Tool requires a bi-directional RS-422 balanced or RS-232 unbalanced serial interface in order to communicate with the LT-Navigation devices. The baud-rate is either: 4.800 or 38.400 baud (configured on the LT-1000 NRU DIP-switch, see *DIP-switch and LEDs* on page 21).

**NOTE:** It is recommended to use a 'USB to RS-422 converter' for easy interfacing in-between the PC (LT-Service Tool) and the LT-1000 NRU. Interconnection diagrams are illustrated in *Connecting LT-Service Tool* on page 25.

#### Automatic mode:

- Step 1: Double click on the LT-Service\_vX.XX.exe file to start the program
- Step 2: The LT-Service Tool will automatically search all COM ports on the PC to identify potential LT-Navigation devices connected to the PC. Devices found, will be shown in a list, as illustrated in Figure 43.
- Step 3: If the LT-Service Tool finds more than one LT-Navigation device, then type the number of the device in the list to be connected with, e.g. "1" and "Return". If only one device is found, then the LT-Navigation device will automatically connect.

**Manual mode:**

- Step 1: Start cmd.exe (Windows command prompt).
- Step 2: Navigate to the directory where the LT-Service Tool is stored.
- Step 3: In the cmd prompt write: "LT-Service\_vX.XX.exe -p COM25 -b 4800" to launch the program (depends on the version of the LT-Service Tool (X.XX = 1.01), PC COM port, and the baud rate for which the LT-1000 NRU is configured).

**LT-Service Tool functions**

The key functions of the LT-Service Tool are listed here. For a complete list of functionality and commands, see *App. F – LT-Service Tool* on page 41.

**Key features:**

- Configuration of the GNSS Receiver (GPS, SBAS, QZSS, BeiDou and GLONASS)
  - Default configuration: GPS, SBAS, QZSS and GLONASS
- Configuration of mounting offset
  - Heading, Roll, Pitch, Altitude (height above sea level)
- Status of the LT-1000 NRU
  - Power On Self-Test (POST)
  - Continuous Monitoring (CM)
  - General status
- Monitoring of NMEA 0183 data
  - Live NMEA 0183 sentences (to inspect valid output from the LT-1000 NRU device)
- Live navigations data
  - Navigation window to display live data (up-date-rate = 1 second)
- Automatic generation of a Diagnostic Report
- Upload of new application software

**List of commands**

All available commands in the LT-Service Tool are described in details when using the "help" command, see *App. F – LT-Service Tool* on page 41. Some of the most used commands are presented here:

- |                                |   |
|--------------------------------|---|
| "help"                         | Lists all commands supported by the LT-Service Tool and the LT-1000 NRU     |
| "set heading <heading>"        | Calculates heading offset and compensate                                    |
| "set rotation offset auto"     | Levelling pitch and roll to zero  |
| "set vertical offset <height>" | Compensate barometer to sea level   |
| "set gnss receiver <id> <id>"  | Select the following type of satellites: GPS, SBAS, QZSS, GLONASS or BeiDou |
| "diag"                         | Generate a Diagnostic Report  |
| "upload <filename>"            | Upload a new application image (absolute or relative file path)             |
| "reboot"                       | Reboot device (for configuration to take affect)                            |
| "post", "event" & "status"     | Prints Power On Self-Tests (POST), events (CM) and status                   |

**GNSS satellite receiver configuration**

The LT-1000 NRU is by default configured to the following GNSS satellite reception:

GPS, SBAS, QZSS and GLONASS

For a complete list of possible configurations, see Table 6, which may be configured using the LT-Service Tool. For further information on the LT-Service Tool, see *Configuration using LT-Service Tool* on page 29.

GNSS Satellite Receiver Configuration	
Configuration	GNSS Satellites
Default	GPS, SBAS, QZSS, GLONASS
Option 1	GPS, SBAS, QZSS, BeiDou
Option 2	GPS, SBAS, QZSS
Option 3	GPS, QZSS
Option 4	GLONASS
Option 5	BeiDou

TABLE 6: GNSS SATELLITE RECEIVER CONFIGURATION

**Mounting offset adjustment**

To get the best possible performance with the LT-1000 NRU, it is required to perform a mounting offset adjustment after physical installation of the device, see procedure below.

Mounting offset procedure:

- 1) Physical installation of LT-1000 NRU (this includes heading alignment with the centerline of the ship).
- 2) Perform a Deviation calibration as described in *Deviation calibration* on page 27.
- 3) Roll and pitch adjustment
  - a. Use the following LT-Service Tool command: “set rotation offset auto”. This command will automatically set roll and pitch level to zero, for the current orientation of the ship.
- 4) Heading adjustment
  - a. Use the following LT-Service Tool command: “set heading offset <offset>” or “set heading <heading>” to adjust the heading offset of the installation. It is recommended to perform a bearing against a known object on the sea chart and then calculate the heading offset.
- 5) Vertical height adjustment
  - a. Use the following LT-Service Tool command: “set vertical offset <height>”, where height is defined in meters. The vertical height adjustment is required for correct output of the pressure above sea level.

By performing the steps specified in the above mounting offset adjustment procedure the end-user of the product will get the best possible performance from the LT-1000 NRU.

**Verify a subsequent deviation calibration**

There are two ways to verify a sub-sequent deviation calibration:

- After a successful deviation calibration (a new deviation calibration is stored in the device), the LT-1000 NRU will suspend the heading output in 10 seconds (this is supported in LT-1000 NRU SW v1.02 or newer).
- Use the following LT-Service Tool command: “status”. The status command will display the latest deviation calibration with a time stamp.

## Service and repair

This section describes what the end-user must do in case of required service or repair.

**NOTE:** The LT-1000 NRU does not require any scheduled maintenance or service. Make sure that the product is installed, as described in this manual, before making contact to the distributor or dealer for further assistance.

For troubleshooting the LT-1000 NRU, see *Troubleshooting* on page 33.

If the LT-1000 NRU for some reason does not work as described in this manual, make contact to the distributor or dealer, from where the product was originally bought. The distributors or dealers will have experience and know-how to assist with further technical support and troubleshooting.

### Contacting the distributor/dealer:

- 1) Make sure to have the product name (LT-1000 NRU), Part Number (P/N: 51-100142), and the unit serial number (S/N: XXXXXXXX) identified. The unit serial number is listed on the outside of the device.
- 2) Write a technical report about the observation or error. If possible, attach a picture of the installed product and include a wiring diagram. If possible, make a diagnostic report with the LT-Service Tool (see *Configuration using LT-Service Tool* on page 29).
- 3) Send all information to the local distributor or dealer.

**IMPORTANT:** Unless otherwise agreed, the end-user shall always coordinate service and repair issues directly with the distributor or dealer. This practice also applies for returning of products for service and repair.

All information that will get back to Lars Thrane A/S, either directly or indirectly, will be handled with confidentiality. End-user sensitive data will not be shared with any third party without prior written acceptance from the involved parties.



## Troubleshooting

Before contacting the distributor or dealer for support, please check the following troubleshooting guide.

### Troubleshooting guide:

- 1) Power cycle the unit to verify that the problem still exists
- 2) Is the communication cable properly connected?  
For more information on connecting cables, see *Connecting* on page 20.
- 3) Check the status of the Red and Green LEDs.  
If everything is correct, then the green LED shall lit and the red LED shall non-lit.  
For further details on the LEDs, see *DIP-switch and LEDs* on page 21.
- 4) Check that the DIP-switch has been configured properly.  
NMEA 0183: 4.800 or 38.400 baud (factory default: 4800 baud)  
NMEA 2000: 'Open' or 'Terminated' (factory default: 'Open')  
For further details on the DIP-switch, see *DIP-switch and LEDs* on page 21.
- 5) Using NMEA 2000 - check your navigational equipment for correct selection of the LT-1000 NRU as preferred source (Heading, GPS, Environmental). Check that the LT-1000 NRU is supporting the expected NMEA 2000 PGNs; see *App. E - NMEA 2000* on 40.
- 6) Using NMEA 0183 - check your navigation equipment for correct baud rate. Check that the LT-1000 NRU is supporting the expected NMEA 0183 Sentences; see *App. D - NMEA 0183* on page 38.
- 7) Connect the LT-Service Tool (see *Connecting LT-Service Tool* on page 25 and *Configuration using LT-Service Tool* on page 29). Check and record the following commands in the LT-Service Tool:
  - a. Write "status" and check for errors and warnings
  - b. Write "nav" and verify navigation data is as expected
  - c. Write "mon" to monitor NMEA 0183 output
- 8) If any configuration has been applied in the LT-Service Tool, make sure that you have used the "reboot" command and check that the new configuration is properly configured after the LT-1000 NRU has power up again.

If none of these troubleshooting steps have re-solved the problem, please contact your local distributor or dealer for further action and support.

**NOTE:** It is recommended, that the end-user makes contact to the local distributor or dealer for technical support on the product, as they have information and experience with the product.

# App. A - Outline Drawings

## LT-1000 with Pole Mount

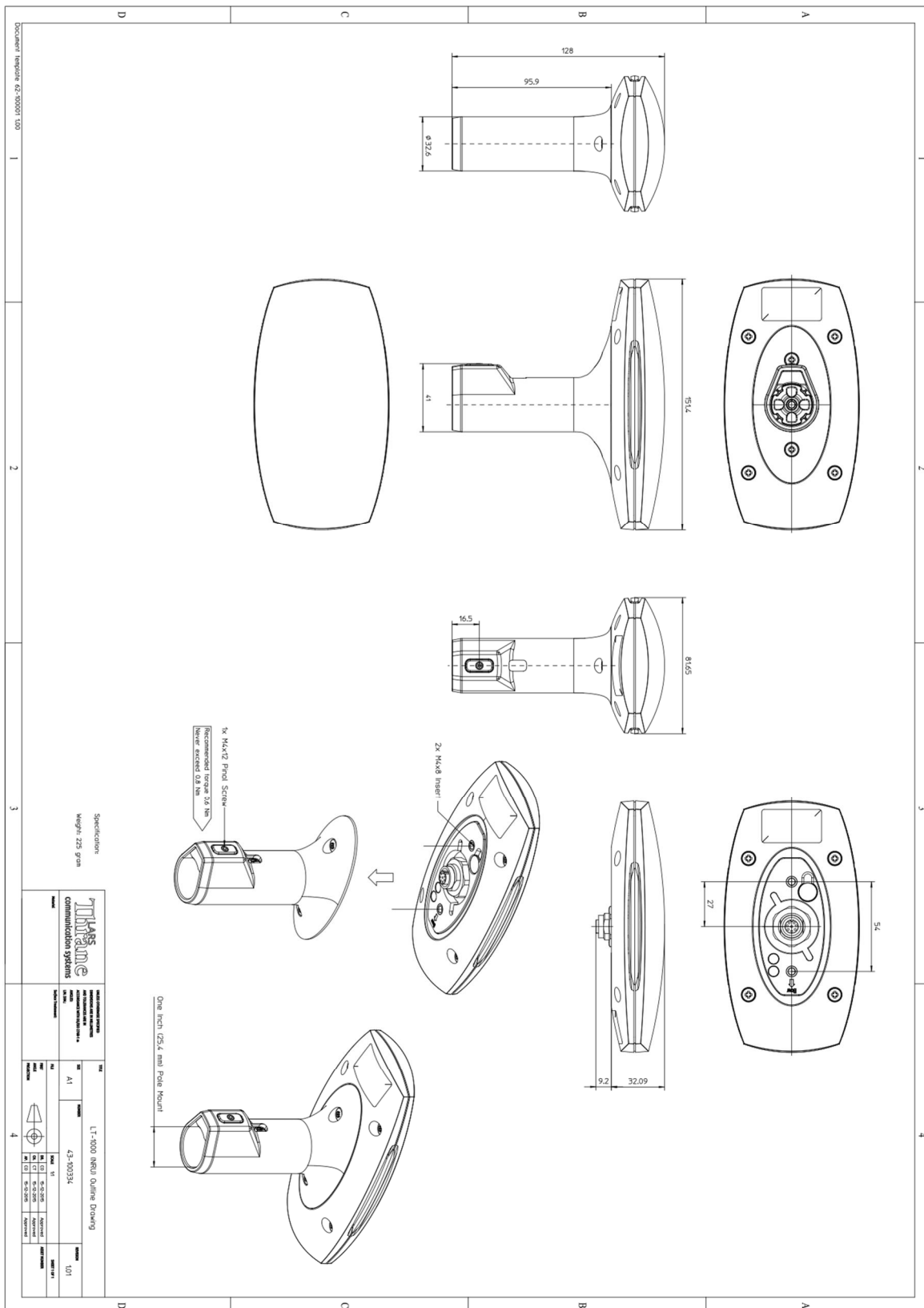

### LT-1000 Roof Mount

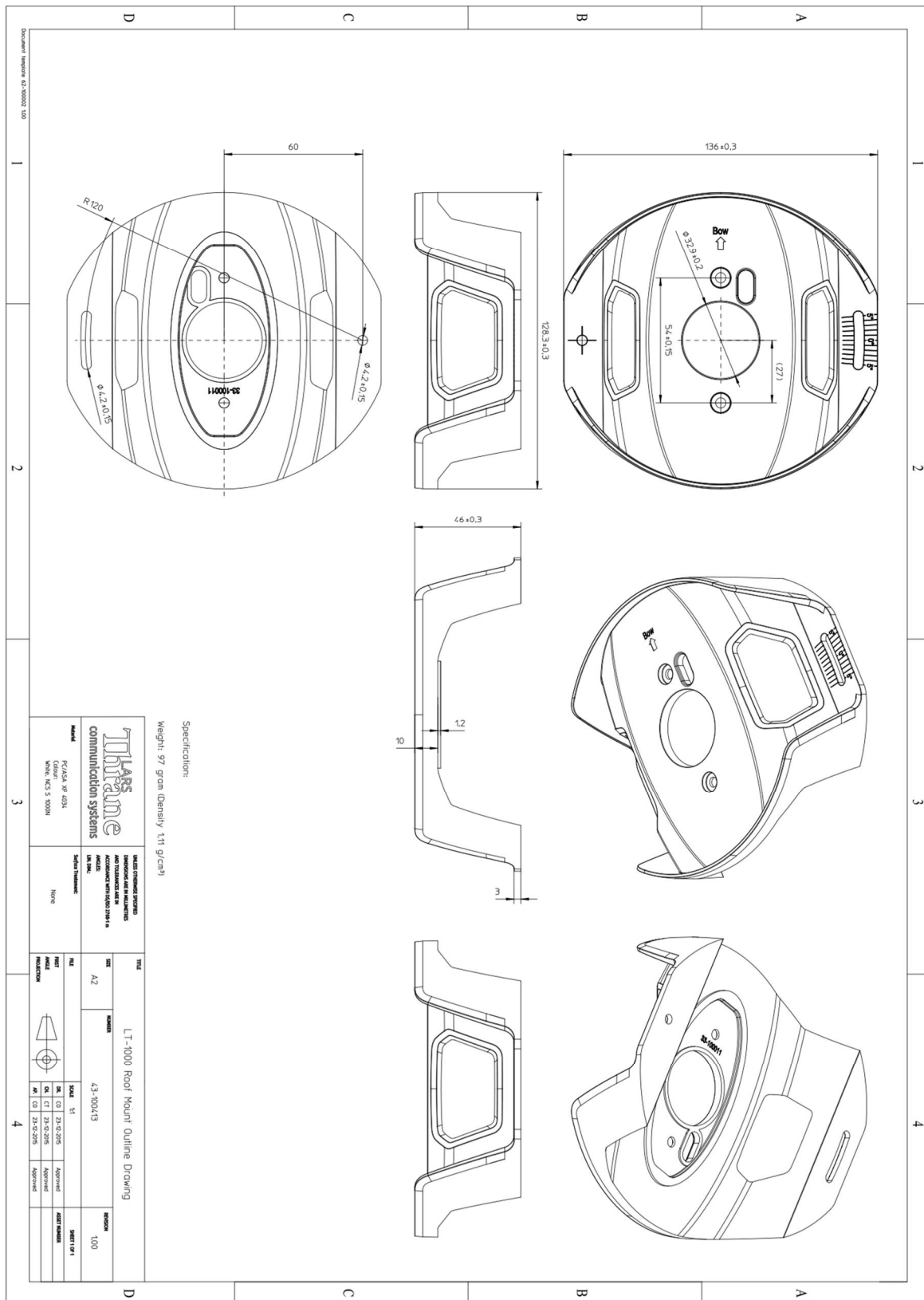

## App. B - Performance

LT-1000 NRU Performance <sup>1</sup>			
Data	Accuracy	Resolution	Range/Comments
Heading <sup>2</sup>	Static: < 0.5° (rms) Dynamic: < 1.5° (rms)	0.1°	Heading is calculated with input from Sensor-fusion technology and Kalman filtering
Position <sup>3</sup>	GNSS: < 2.5 m (auto), SBAS: < 2 m	0.1 m	CEP, 50%, 24 hours static, -130 dBm, > 6 SVs By default the GNSS receiver is configured for GPS/GLONASS & SBAS reception Time-To-First-Fix (cold acquisition): 26 s.
Speed	0.1 knot	0.1 knot	0 to 970 knots
Roll/Pitch	Static: < 0.5° (rms)	0.1°	± 90°
Rate of turn	< 1°/s	0.1°/s	0 to 45°/s
Air Pressure	1 hPa	0.1 hPa	800 to 1100 hPa
Air Temperature <sup>4</sup>	1°C (1.8°F) 2°C (3.6°F)	0.1°C (0.1°F)	0°C to +55°C (32°F to +131°F) -40°C to 0°C (-40°F to +32°F)

1: The NRU performance may be subject to degradation caused by an improper installation.

2: The dynamic heading accuracy is specified with roll/pitch less than ± 45° and ROT ≤ 45°/s.

3: The LT-1000 NRU has an immunity filter against Iridium and Inmarsat transceivers

4: Solar radiation and environmental conditions will affect the measured air temperature (accuracy is specified as on-board sensor performance)

## App. C – Specifications

<b>LT-1000 NRU Specifications</b>	
Certification and standards <sup>1</sup>	CE, IEC 60945, IEC 60950, EN 300 440, EN 301 389, FCC, IC, RoHS, WEEE NMEA 0183, NMEA 2000
Equipment class	Protected, according to IEC 60945
Weight, with pole mount	240 g (0.53 lbs)
Weight, with roof mount	281 g (0.62 lbs)
Dimensions, with pole mount	151.4 x 81.6 x 128.0 mm (5.96 x 3.21 x 5.04 in)
Dimensions, with roof mount	151.4 x 136.0 x 46.0 mm (5.96 x 5.35 x 1.81 in)
Temperature, operational (ambient)	-40°C to +55°C (-40°F to +131°F)
Temperature, storage (ambient)	-40°C to +85°C (-40°F to +185°F)
Vibration, operational	IEC 60945 (sine) & Proprietary Maritime Random profile (240 h)
Vibration, survival	Proprietary Maritime Random profile (100 h)
Vibration, shock	Proprietary Maritime profile (60 g pk, 11 ms)
Waterproof rating	IPX6
Humidity	95% non-condensing @ 40°C
Wind, operational	80 knots (93 MPH)
Wind, survival	110 knots (127 MPH)
Ice, survival	25 mm (1 in)
Solar radiation	1120 W/m <sup>2</sup>
Communication interface	8-pin female connector for NMEA 0183, NMEA 2000 and power
Input voltage	9-40 VDC
Power consumption	< 1 W (@ 12 VDC)
Load Equivalent Number (LEN)	2
Compass safe distance standard	0.3 m (1 ft)
Compass safe distance steering	0.3 m (1 ft)
Mounting, pole mount	25.4 mm (1 in)
Warranty	2 year
Maintenance	None

1: RoHS, WEEE, and NMEA 2000 is pending for final registration and certification.

## App. D - NMEA 0183 Sentences

The LT-1000 NRU is compliant with version 4.00 of the NMEA 0183 standard. The following table lists the supported sentences.

NMEA 0183 Sentences		
Sentences	Description	Rate
<b>4800 baud</b>		
GNGGA	Datum Reference	1 Hz
GNVTG	Course Over Ground and Ground Speed	1 Hz
GNZDA	Time and Date	1 Hz
HCHDG	Heading and Magnetic Heading Variation	1 Hz
HCHDM	Magnetic Heading	1 Hz
HCHDT	True Heading	10 Hz
HCROT	Rate of Turn	1 Hz
PFEC,GPatt	Attitude	1 Hz
WIMDA <sup>1</sup>	Meteorological Composite	0.5 Hz
<b>38400 baud</b>		
GNDTM	Datum Reference	1 Hz
GNGGA	GPS Fix Data	1 Hz
GNLL	Position Latitude/Longitude WGS84	1 Hz
GNGSA	GNSS DOP and Active Satellite	1 Hz
GNRMC	Mini Specific GNSS Data	1 Hz
GNVTG	Course Over Ground and Ground Speed	1 Hz
GNZDA	Time and Date	1 Hz
GPGSV <sup>2</sup>	GNSS Satellites in View	1 Hz
HCHDG	Heading and Magnetic Heading Variation	10 Hz
HCHDM	Magnetic Heading	10 Hz
HCHDT	True Heading	10 Hz
HCROT	Rate of Turn	10 Hz
HCTHS	True Heading and Status	10 Hz
PFEC,GPatt	Attitude	10 Hz
WIMDA <sup>1</sup>	Meteorological Composite	2 Hz
WIXDR <sup>3</sup>	Transducer Measurements	2 Hz

For all GNSS sentences, talker ID "GN" can be configured to be "GP"

1: Pressure (inHg, Bar) and Air Temperature (°C) only

2: Talker ID (GP, GL, GB) depends on satellite system (GPS/SBAS, GLONASS, BeiDou)

3: Pressure (Pa) and Temperature (C)

### GNSS Talker Identifier

The first two characters in the address field of an NMEA 0183 sentence is the Talker Identifier (e.g. “HC” in the address field “HCHDG”). The Talker Identifier may be used to determine the source of a sentence, when it can have multiple sources. In case of the GNSS related sentences (DTM, GGA, GLL, GSA, GSV, RMC, VTG, ZDA), the Talker Identifier can be used to determine from which specific GNSS system the data originates:

GNSS Talker Identifier	
Talker Identifier	GNSS Type
GB	BeiDou
GL	GLONASS
GN	Multiple GNSS'
GP	GPS, SBAS, or QZSS

TABLE 7: GNSS TALKER IDENTIFIER

GN Talker Identifier is a special case that indicates the sentence data originates from multiple GNSS systems. This is the case when the LT-1000 is configured (see *GNSS satellite receiver configuration* on page 31) to use multiple GNSS systems: GPS + GLONASS or GPS + BeiDou.

The GSV sentence will never be sent with Talker Identifier GN as it will ever only contain data from one GNSS system. If the LT-1000 NRU is configured to use multiple GNSS systems, the GSV sentence will be repeated for each GNSS system and the Talker Identifier of each GSV sentence will indicate the specific GNSS system to which it applies.

### MDA

The Meteorological Composite (MDA) sentence can convey more information about the environment than the LT-1000 NRU supports. In compliance with the NMEA 0183 standard, data fields for which LT-1000 NRU has no data will be null fields.

Here is an example of an MDA sentence outputted from an LT-1000 NRU containing air pressure and air temperature:

\$WIMDA,29.29,I,0.9918,B,19.8,C,,C,,,C,,T,,M,,N,,M\*23

### XDR

The XDR sentence Transducer ID field is not standardized by the NMEA 0183 standard and is thus proprietary. Lars Thrane A/S has defined the following proprietary Transducer IDs:

XDR Proprietary Transducer ID's		
Transducer ID	Transducer	Unit
ATMO	Pressure (P)	Pascal (P)
TEMP	Temperature (C)	Celcius (C)

TABLE 8: XDR TRANSDUCER ID'S

Here is an example of an XDR sentence outputted from an LT-1000 NRU containing air pressure and air temperature:

\$WIXDR,P,99178,P,ATMO,C,19.8,C,TEMP\*6B

### App. E - NMEA 2000 PGNs

The LT-1000 NRU is compliant with version 2.000 of the NMEA 2000 standard and version 2.000 of the NMEA Network Database. The following table lists the supported PGNs.

<b>NMEA 2000 PGNs</b>		
<b>PGN</b>	<b>Description</b>	<b>Rate</b>
<b>Periodic PGNs</b>		
126992	System Time	1 Hz
126993	Heartbeat	< 0.1 Hz
127250	Vessel Heading	10 Hz
127251	Rate of Turn	10 Hz
127257	Attitude	10 Hz
127258	Magnetic Variation	1 Hz
129025	Position, Rapid Update	10 Hz
129026	COG & SOG, Rapid Update	4 Hz
129029	GNSS Position Data	1 Hz
129044	Datum	0.1 Hz
129539	GNSS DOPs	1 Hz
129540	GNSS Sats in View	1 Hz
130311	Environmental Parameters	2 Hz
130312	Temperature	0.5 Hz
130314	Actual Pressure	0.5 Hz
130316	Temperature, Extended range	0.5 Hz
<b>Requestable PGNs</b>		
126464	PGN List (Transmit and Receive)	-
126996	Product Information	-
126998	Configuration Information	-
129538	GNSS Control Status	-
<b>Oher PGNs</b>		
059392	ISO Acknowledgement	-
059904	ISO Request	-
060928	ISO Address Claim	-
065240	ISO Commanded Address	-
126208	NMEA Request/Command/Acknowledge	-



## App. F – LT-Service Tool (commands)

```

LT-Service Tool
LT-Service Tool, 71-100166, version: 1.01
Type 'help' to get a list of all available commands
searching for LT navigation devices:

No Model    Part no    Serial    SW ver    Port    Baudrate
1  LT-1000    51-100142  00001001  1.01    COM3    38400

Connected to LT-1000 (serial:00001001) at COM3

lt> help
diag [<path>]      Write diagnostic report to file
event             Print list of system events
get heading offset Print the current heading offset
get roll offset   Print the current roll offset
get pitch offset  Print the current pitch offset
get vertical offset Print the current vertical offset relative
                  to the waterline
get mounting offset Print heading, roll and pitch offsets
get gnss receiver Print list of selected GNSS receivers
help             This help text
mon             NMEA-183 monitor
nav            Navigation monitor
post          Power On Self Test (POST) report
quit         Quit program
reboot       Reboot device (system configuration takes effect)
set heading offset <offset> Set heading offset, corrects the actual mounting
                        position
                        The <offset> is in degrees (-180.0 to +180.0)
set roll offset <offset> Set roll offset, corrects the actual mounting
                        position
                        The <offset> is in degrees (-180.0 to +180.0)
set pitch offset <offset> Set pitch offset, corrects the actual mounting
                        position
                        The <offset> is in degrees (-180.0 to +180.0)
set vertical offset <height> Set the vertical offset relative to the waterline
                        <height> is in meters (decimal number)
set rotation offset auto Set roll and pitch offsets automatically.
                        This function requires that the ship is in a
                        stable position
set heading <heading> Heading offset is calculated based on the current
                        heading
                        <heading> is in degrees (0.0 - 360.0)
set gnss receiver <id> <id>.. Select GNSS receivers
                        <id>: GPS, SBAS, QZSS, BeiDou, GLONASS
                        BeiDou and GLONASS can not be selected at the
                        same time
                        The configuration takes effect when the system
                        is rebooted
status          Print status of the device
upload <filename> Upload new software to the device
                        <filename> specifies the name of the software
                        file (extension: lti)
ver            Print the product and software version
                        information

lt>

```

## App. G - Declaration of Conformity

68-100335 Rev. 1.01



### Declaration of Conformity

This declaration of conformity is issued under the sole responsibility of the manufacturer

**Manufacturer:** Lars Thrane A/S

**Address:** Stubbeled 2, 2950 Vedbæk, Denmark

**Product Identification:** LT-1000 Navigation Reference Unit (NRU) PN = 51-100142

**Product Description**

The LT-1000 NRU is a small, compact, and very advanced unit with 12 precision sensors (magnetometers, gyros, accelerometers, barometer, thermometer, and GNSS). With the use of sensor-fusion and Kalman filtering, the LT-1000 NRU outputs: true-heading, roll, pitch, position, speed, air pressure, and temperature real-time, with high precision and resolution. The LT-1000 NRU makes use of the latest technology within GNSS receivers, with market leading acquisition and tracking performance. The LT-1000 NRU is designed and built for the demanding and rough environment at sea and with an operational temperature (ambient) range from -40°C to +55°C (-40°F and +131°F).

**Declaration**

We as manufacturer declare that the above listed product complies with the specification of the EC directive 1999/5/EC. The conformity has been assessed according to the procedure detailed in Annex IV of the R&TTE Directive. The following harmonized standards were applied:

**RF Spectrum:** EN 300 440-2, v1.4.1

**EMC:** EN 301 489-1, v1.9.2 / EN 301 489-3, v1.6.1

**Safety:** EN 60950-1:2006+AC:2011+A11:2009+A1:2010+A12:2011+A2:2013 / EN 60945:2002

Confirmed by Cetecom, Notified Body No. 0682

Year of affixing the CE mark: 2015

**Place and Date**

Vedbæk, 26. October 2015



Peter Thrane, CEO  
Lars Thrane A/S



Lars Thrane A/S  
Stubbeled 2  
DK-2950 Vedbæk  
VAT No. DK-36042443

Phone: +45 88 30 10 00  
Fax: +45 88 30 10 09  
[company@thrane.eu](mailto:company@thrane.eu)  
[www.thrane.eu](http://www.thrane.eu)

Danske Bank  
DKK No. 3874 3874034150  
IBAN-DK0830003874034150  
SWIFT-DABADKKK