



SAAB



R5 SUPREME

NETWORKED AIS FOR SOLAS AND ADVANCED APPLICATIONS

The SAAB R5 SUPREME AIS system is designed for SOLAS vessels and advanced applications such as Secure and Warship AIS. It fully utilises our fifth generation transponder technology, building on the success of the R4 AIS system, which is in operation in over 20,000 ships worldwide.

The R5 system features cutting-edge digital radio design, resulting from more than five years' research into software defined radios.

Sharing radio technology with military grade systems, the R5 technology is a major leap forward into the future of AIS radios.

The highly versatile R5 platform will continue to evolve as new requirements are introduced, and will remain at the forefront of AIS technology for many years to come.

The SUPREME version of the R5 technology provides the user with a flexible, future-proof product. The large colour touch-screen display and multitude of interfaces make the system highly appropriate for integration into modern networked bridge solutions.

FEATURES

- 7" ultra-bright high contrast colour LCD
- Touch screen, keypad and USB keyboard support
- Ethernet, RS-422 and USB interfaces
- Use USB memory for quick software upgrades
- Load/save configuration with USB Memory
- Pilot Plug integrated in display
- Full AIS SART support
- Text messaging
- VHF communication test function
- R4 Navigation Sensor Compatible
- Gimbal or flush mounting
- Water resistant design
- Alarm acknowledge binary port
- Dual AIS systems in Hot Standby configuration



SAAB

TECHNICAL SPECIFICATION

PHYSICAL

Transponder
 Size W x H x D: 227x77x192 mm
 Weight: 2.05 kg

Display
 Size W x H x D: 255x140x84 mm
 Weight: 1.6 kg
 Resolution: 800x480 (WVGA)
 TFT: IPS-Pro
 Touch: Resistive
 Brightness: 800 Nits
 Power input: 12/24 VDC

POWER CONSUMPTION

Transponder: 20 W (60 W peak)
 Control & Display unit: 13 W

GPS RECEIVER (INTERNAL)

50 channels (Ready for DGPS)
 Frequency: L1 (1575.42 MHz)
 Update rate: 1 Hz
 Antenna feed: 5 V DC

Position accuracy (SA off)
 Position <2.0 m: DGPS (CEP)
 Position <2.5 m: GPS (CEP)
 Sensitivity: Tracking -162 dBm
 Cold Start -148 dBm

VHF TRANSCEIVER

AIS receivers: 3
 DSC receivers: 1
 AIS transmitters: 1
 Frequency: 155-163 MHz
 Output power: 1/12.5 W (±1.5 dB)
 Sensitivity: <-111 dBm

ELECTRICAL INTERFACES

Transponder: Ethernet 10/100 Mbit (LWE IEC 61162-450)
 6 RS-422 I/O (NMEA / IEC 61162-1 Ed.4)
 3 Digital In, 3 Digital Out (3x in + 3x out)
 Alarm Relay
 Alarm Relay Output
 Alarm Ack Input
 Silent switch

Display: Ethernet 10/100 Mbit (LWE IEC 61162-450)
 Pilot plug
 USB Host 2.0
 SDHC Reader

ENVIRONMENTAL DATA

IEC 60945 (Protected)
 Operating temperature: -15°C to 55°C
 Storage temperature: -30°C to 80°C

R5 SUPREME AIS SYSTEM INCL. JUNCTION BOX

With its multitude of interfaces the system is designed and very suitable for integration into modern networked bridge solutions.

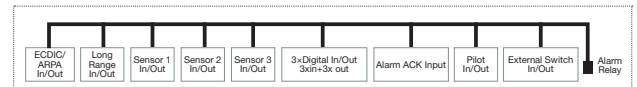
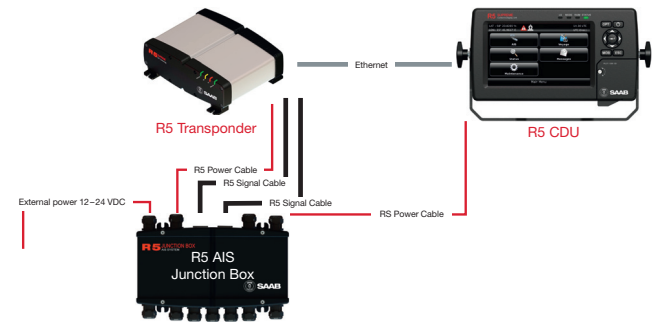

R5 SUPREME Transponder rear view

STANDARDS

ITU-R M. 1371-4 (Class A) 2010
 ITU-R M. 825-3, 1998
 ITU-R M. 1084-5, 2012
 IEC 61993-2 Ed.2, 2012
 IEC 61108-1Ed 2.0 2003
 IEC 60945 Ed. 4.0 2002 incl Corr .1 2008
 IEC 61162-1 Ed 4.0 2010
 IEC 61162-2 Ed 1.0, 1998
 IEC 62288Ed 1.0. 2008

Specifications subject to change without notice

www.saabgroup.com

Security and Defence Solutions
 Saab TransponderTech AB
 Låsblecksgatan 3
 SE-589 41 Linköping, Sweden

tel. +46 13 18 80 00
 fax +46 13 18 23 77